

Description

The E-T-A Solid State Remote Power Controller E-1048-7.. is a transistorised switching device providing both protection and signalisation. It is suitable for all applications where the capabilities of the existing PLC outputs are not sufficient or where no protection against overload and short circuit or wire breakage monitoring of connected loads is provided. The use of a costly, high-capacity output card becomes superfluous when only one or two powerful outputs are necessary.

Using the SSRPC E-1048-7.. in combination with the module 17plus creates a new, very flexible system capable of being subsequently changed or extended. Busbars, pre-wired signal contacts and spring-loaded terminals reduce installation times considerably (see accessories).

Typical applications

Automation

- interface module providing inexpensive power amplification at PLC outputs
- optimum protection of individual loads by monitoring the load circuit

Protection and control of

- motors
- solenoids
- lamps

Features

- Optimum load protection. Available in current ratings of 0.5 A; 1 A; 2 A; 4 A; 5 A. No derating required over entire temperature range!
- Fast short-circuit limitation and disconnection
- Time/current dependent overload disconnection (simulating thermal-magnetic CBE trip curve)
- Remote control
- Fault indication: LED and signal output for overload/short-circuit signalisation, and wire break indication in the OFF condition (version -700 and -710) and in the OFF and ON condition (version -702 and -712)
- Fault storage: version -710; -712 and -713
- Physically isolated fault indication
- Compact plug-in type
- Plug-in design for use with power distribution system module 17plus
- Integral pre-wiring of common supply and signal contacts

Ordering information

Type No.	
E-1048	SSRPC for PLC outputs
Version	
700	wire break indication in OFF condition (standard)
710	wire break indication in OFF condition and fault storage
702	permanent wire break indication
712	permanent wire break indication and fault storage
703	without wire break indication
713	without wire break indication with fault storage
Voltage rating	
DC24 V	DC 24 V (standard)
Current ratings	
	0.5 A
	1.0 A
	2.0 A
	4.0 A
	5.0 A
E-1048 - 700	DC24 V 1.0 A ordering example



E-1048-7..

Technical data (T_{ambient} = 25 °C; at U_N)

Load circuit

Voltage rating U_S DC 24 V (18...36 V)
 Current rating I_N 0.5 A; 1 A; 2 A; 4 A; 5 A
 (other ratings to special order)
 Closed-circuit current I_{Contr} typically 0.3 mA

Min. load current

Version -700/-710:

wire break indication in OFF condition

Optional: wire break indication in OFF and ON condition

wire break ind. in OFF cond. R_{load} typically 500 kΩ

wire break ind. in ON cond. I_{load} < typ. 130 mA (0.5/1 A unit)

I_{load} < typ. 500 mA (2/4/5 A unit)

Voltage drop U_{DSmax} 0.15 V; 0.3 V; 0.1 V; 0.2 V; 0.3 V
 Switch-on/switch-off time t_{on}/t_{off} typ. 300 μs/700 μs with resistive load

Overload disconnection approx. 1.5 (± 0.3) × I_N after approx. 100 ms

Short-circuit current (self-limiting) max. 25 A (with 0.5 A and 1 A current ratings)

max. 75 A (with 2 A/4 A/5 A current ratings)

Short-circuit disconnection < 250 μs

Control input

Control level between IN+ and GND
 Voltage rating DC 24 V
 Voltage controlled input U_E DC 0 V < low level < 5 V
 DC 8.5 V < high level < 36 V
 Input current I_E 1...10 mA (8.5...36 V)

Max. switching frequency f_{max} 1 kHz

Reset time after short-circuit/overload disconnection 1 ms

Fault indication output F

relay contact
 max. switching voltage DC 150 V
 AC 125 V

max. interrupting capacity DC 30 W
 AC 60 W

limiting continuous current 1 A

General data

Temperature range 0 °C...+60 °C
 Insulation voltage DC 500 V > 10 MΩ

(IEC 60664/VDE 0110)
 Mass 28 g

Technical description

At the correct input voltage ($> 8.5\text{ V}$), the SSRPC will switch on a power transistor to connect the load to the plus pole of the load circuit supply (U_S).

The transistor will switch off when

- the control voltage (U_E) is removed
- there is a short-circuit/overload in the load circuit.

Status indication is provided by two LEDs (red and yellow).

Simulated thermal-magnetic overload protection occurs at approx. 1.5 times rated current. See time/current characteristic curves.

The SSRPC is fitted with blade terminals DIN 46244-A6.3-0.8 and is suitable for plug-in mounting with various E-T-A sockets or **module 17plus** (see Accessories).

Control circuit

ON condition:

If a voltage higher than 8.5 V is applied to the input terminals (+IN against GND), the control current (from the PLC) will flow through the opto coupler. The output transistor will be conductive, status indication by yellow LED.

OFF condition:

A control voltage lower than 5 V will switch the output transistor off.

Load circuit

The load circuit switches depending on the control signal ("0" or "1"). It is electronically monitored for faults. In the event of a short-circuit the circuit is disconnected after max. 250 μs whilst upon inadmissible overload it is disconnected according to the time/current curves shown.

Fault indication output F

The fault indication circuit is physically isolated from the load and control circuits via a relay.

In the OFF condition, this circuit (with closed contact) will provide wire break indication, with the transistor output being open.

The versions with fault storage (-702/-712 and -713) store the fault signal until the control voltage is re-applied.

Visual fault indication by red LED.

Connection diagram

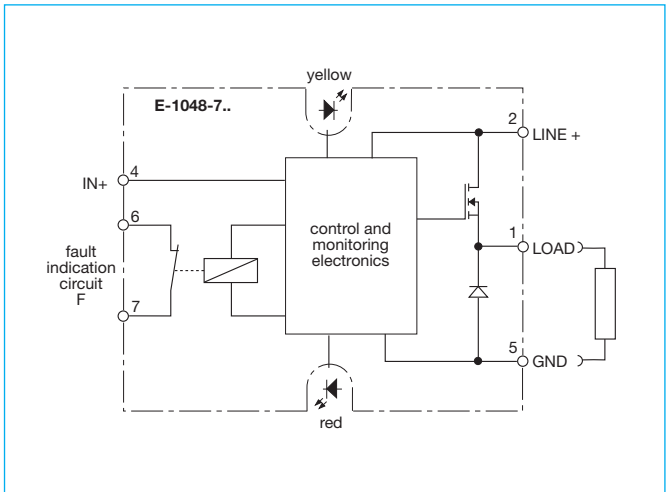

Typical time/current characteristics ($T_A = 25\text{ }^\circ\text{C}$)

0.5 A and 1 A

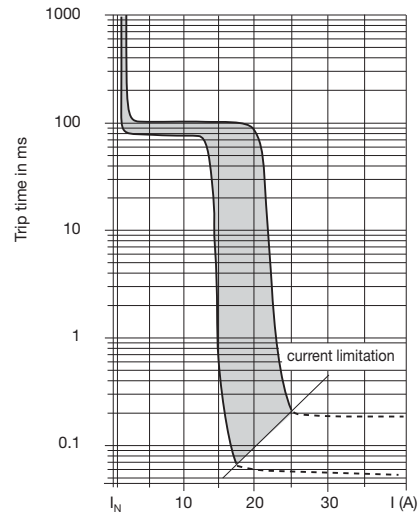

2 A and 4 A

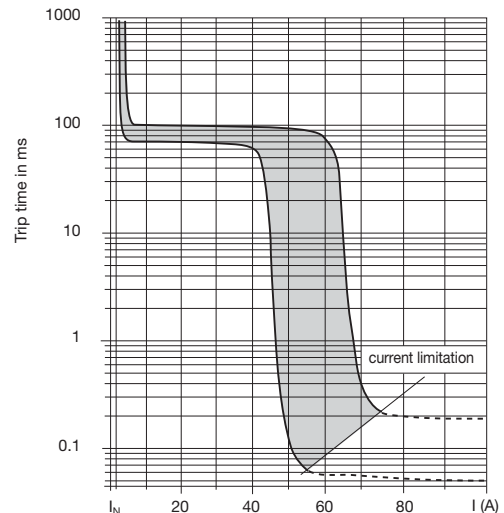

Dimensions

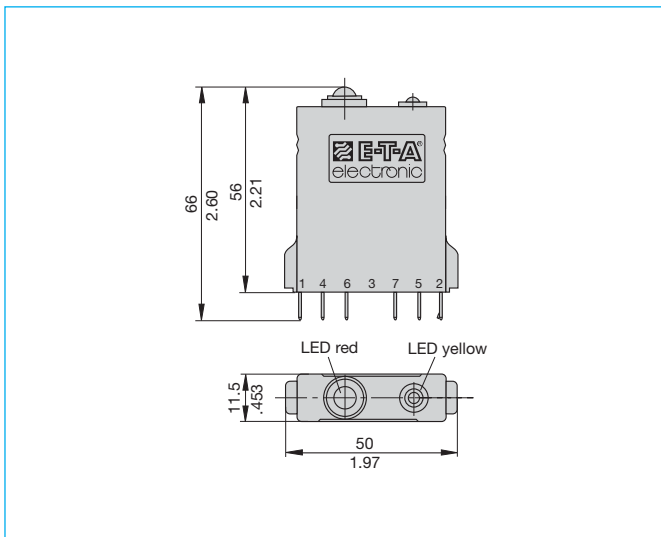

This is a metric design and millimeter dimensions take precedence ($\frac{\text{mm}}{\text{inch}}$)

Functional diagrams E-1048-7..

Functional diagram E-1048-7..
wire break indication

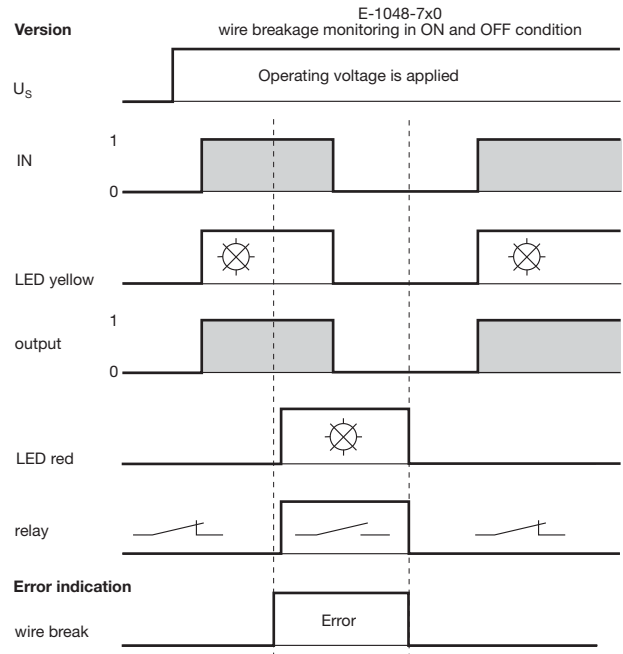
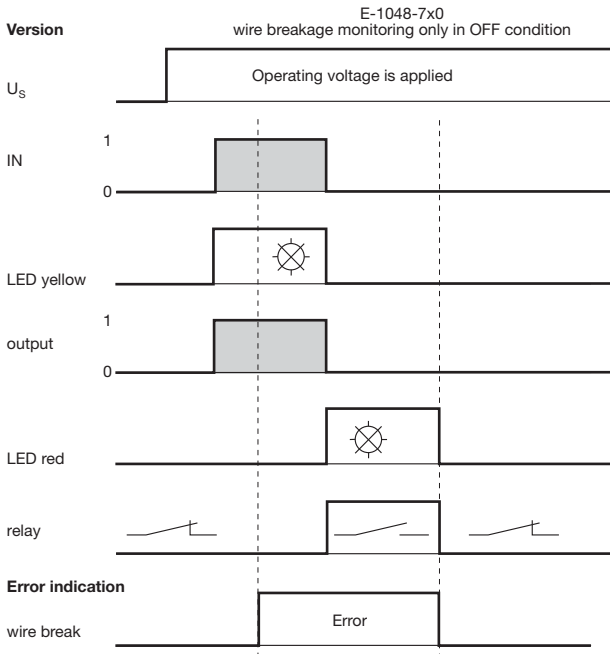

Functional diagram E-1048-7..
overload /short-circuit indication

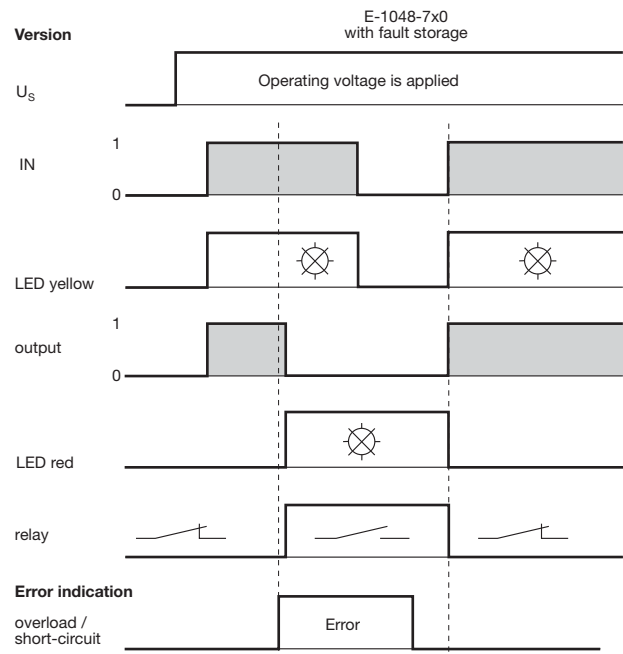
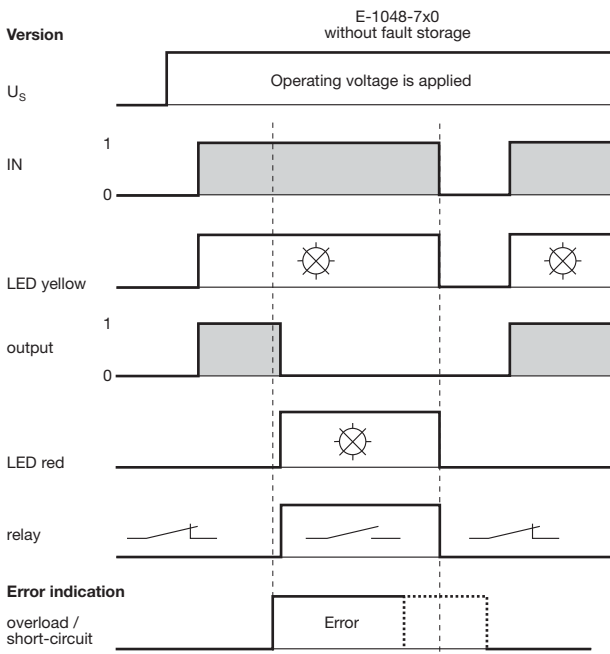

1 0 IN = input set / output = switched through

LED lights

Connection diagram

Solid State Remote Power Controller E-1048-700 with Module 17plus

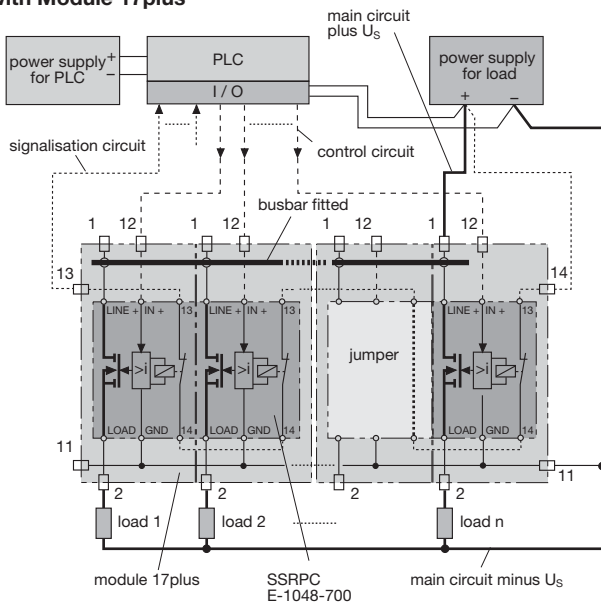

Wiring diagram

Separate power supply for load, PLC I/O and signal loop

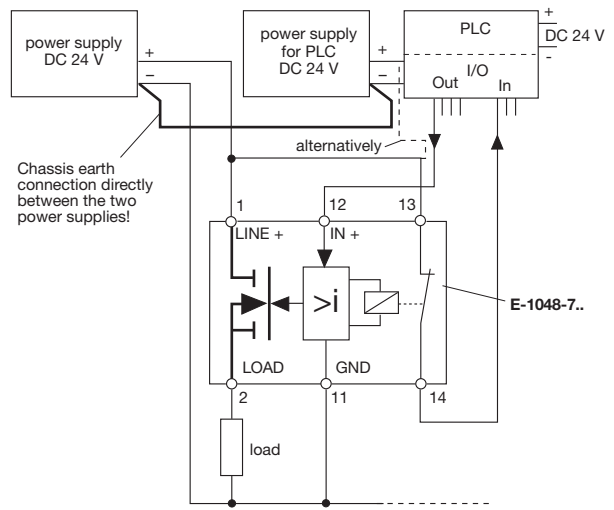

Caution: If there is no firm chassis earth connection when using several separate power supplies, the connected fault indication loop may lead to intermittent operation of the SSRPC and resultant operational hazards.

Wiring diagram

Common power supply for load, PLC I/O and signal loop

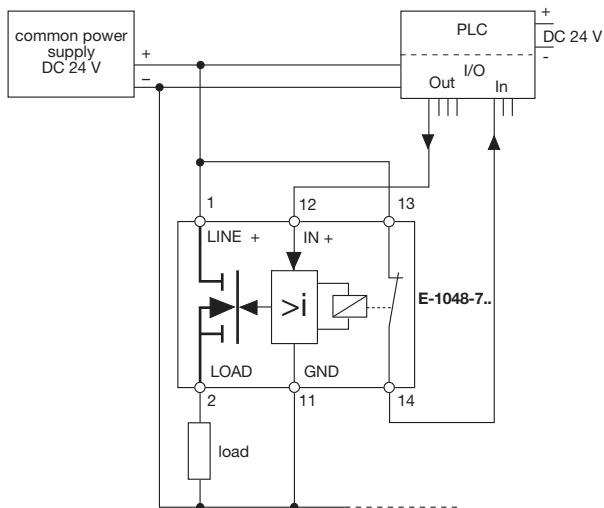

6

Accessories for E-1048-7..

Description

Module 17plus is a power distribution system for use with SSRPC E-1048-7.. for PLC outputs.

Each module accommodates two SSRPCs with an individual housing width of only 12.5 mm and fits onto all industry standard mounting rails. The two-way modules can be interconnected to provide as many ways as required with a terminal block fitted at each end for connection of signalling circuits. A distribution busbar can be fitted on the supply side of the modules (positive pole) though each pole of multipole circuit breakers must be individually connected. Electrical connections are by means of spring-loaded terminals. The reference potential for the electronic amplifiers (GND pin 11) is also looped through and to the terminals connected at the sides. Control of the amplifiers (IN+), referenced to GND, is per channel via the separate terminal 12 beside the LOAD terminal. The SSRPC has an integral signal contact (break contact) used for group signalisation. Therefore the terminals of all break contacts are connected in series in the module 17plus and are connected to the terminal blocks via two terminals (13, 14). The module is designed to accommodate a probe for series connection continuity tests. When multipole circuit breakers are fitted auxiliary contacts are required for each pole. Individual circuit breaker signalisation is achieved through use of the break contacts (which close in the event of failure) connected in parallel by means of terminals on each module. The signalling circuitry between modules and the internal prewiring for the potential is automatically connected when the modules are linked together. Meets the requirements of UL60950.

Ordering information

17PLUS-Q02-00	Module 17plus, centre piece, two-way
17PLUS-QA0-LR	one each left- and right-side terminal block for supply feed from the side by means of screw terminal, connection of signalisation etc.



17plus

Technical data

Connection	Spring-loaded terminals for solid conductors and stranded cables with and without wire end ferrules. Please use appropriate screw driver size (SD) for removing the spring loaded terminals.
LINE feed (1):	spring-loaded terminals for 1.5-10 mm ² , (AWG 20 - AWG 10) SD 2 (0.8x4.0)
LOAD output (2):	spring-loaded terminals for 0.25-4 mm ² , (AWG 24 - AWG 12) SD 1 (0.6x3.5)
Reference potential GND and signalisation terminals (11, 13, 14):	spring-loaded terminals for 0.25-2.5 mm ² , (AWG 24 - AWG 14) SD 1 (0.6x3.5)
control IN+ terminal (12)	spring-loaded terminal for 0.25-1.5 mm ² , (AWG 24 - AWG 16) SD 0 (0.4x2.5)
Test probe for testing the group signal for line interruption: ≤ 2 mm Ø	
Voltage rating (without SSRPC):	AC 433 V; DC 65 V
Current rating (without SSRPC)	
LINE feed (1)	50 A
LOAD output (2)	25 A
Reference potential GND (11)	10 A
Control IN+ (12)	1 A
Group signal / (13-14)	1 A
Internal resistance values (without SSRPC)	
LINE-LOAD (1-2)	≤ 5 mΩ
Group signal (13-14)	≤ 8 mΩ/per pole + 5 mΩ for each additional module
Busbar for power distribution	
insulated busbar (blue or red):	I _{max} 32 A
non-insulated busbar:	I _{max} 50 A
(The non-insulated busbar, too, meets brush contact safety standards when fitted.)	
Dielectric strength	
between main circuits (without busbar):	1,500 V
main circuit to auxiliary circuit:	1,500 V
between auxiliary circuits:	1,500 V
Mass: Module 17plus (centre piece)	approx. 85 g
terminal blocks (pair)	approx. 30 g

Dimensions

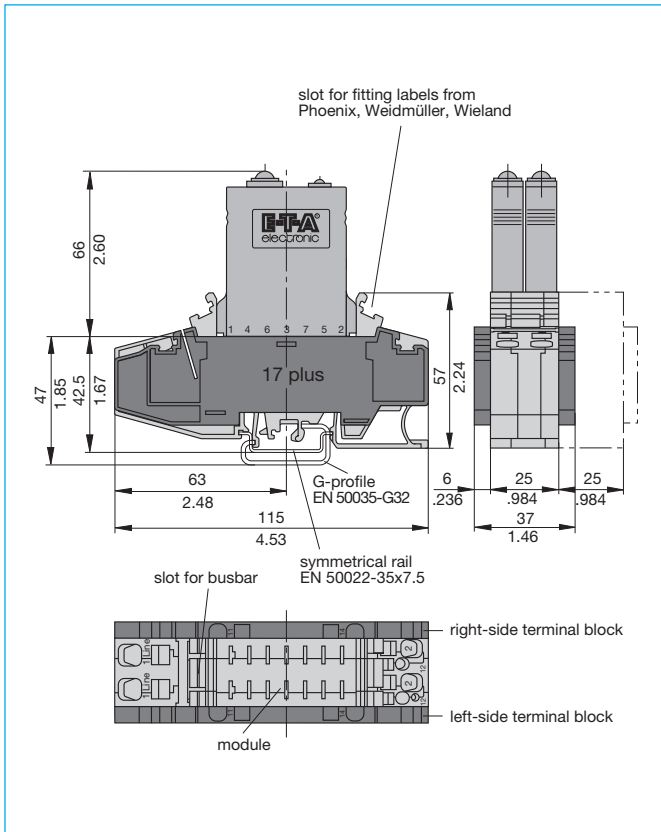

This is a metric design and millimeter dimensions take precedence ($\frac{\text{mm}}{\text{inch}}$)

Connection diagram

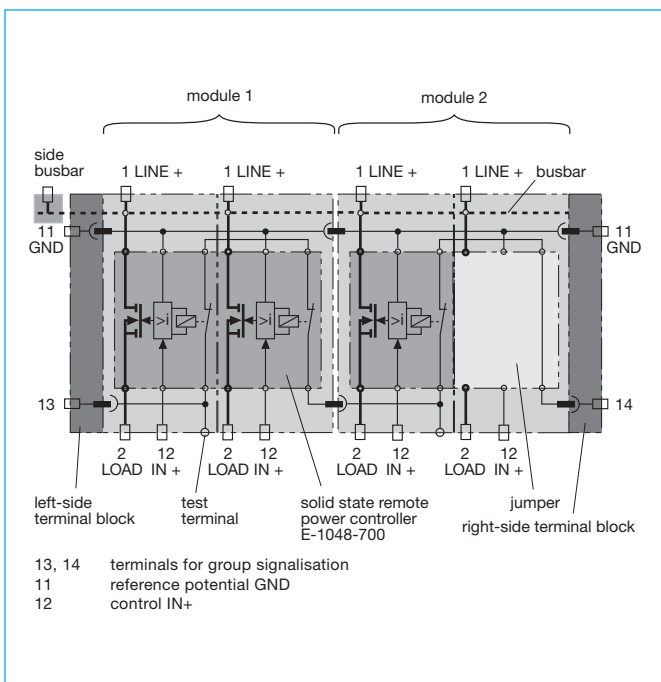

Installation example

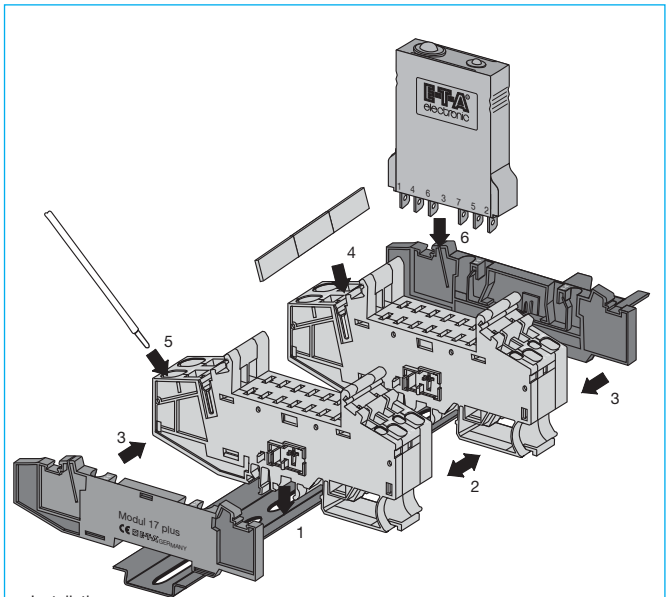

Installation:

- 1 Clip modules onto DIN rails.
- 2 Push modules together (side-by-side).
- 3 Snap on right-side and left-side terminal blocks.
- 4 Cut busbar to required length and fit on supply side of the modules.
- 5 Connect line feed with spring-loaded terminals.
- 6 Plug in SSRPC E-1048-7...

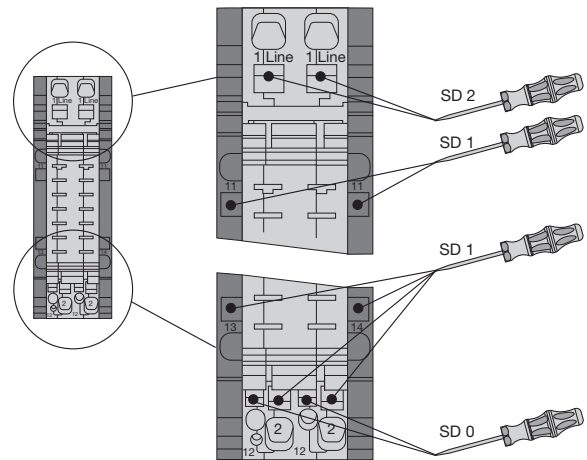

Connection and disconnection of cables with screw driver

Pin selection, fitted with E-1048-7..

E-1048-7..	Module 17plus	
LINE + (2)	(1)	
GND (5)	(11)	
F 7 (7)	(13)	
F 6 (6)	(14)	
IN+ (4)	(12)	
LOAD (1)	(2)	

Accessories

Busbar 32 A

- X 222 005 01 blue insulation, 500 mm/19.68 in.
- X 222 005 02 red insulation, 500 mm/19.68 in.
- X 222 005 03 grey insulation, 500 mm/19.68 in.

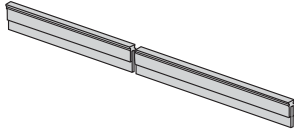

Busbar 50 A

- Y 307 016 01 non-insulated, 500 mm/19.68 in.

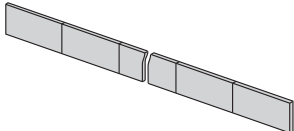

Busbar 50 A

- Y 307 016 11 non-insulated, 500 mm/19.68 in.

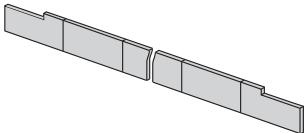

End bracket
X 222 004 01

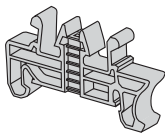

Screw terminal for busbar
X 211 156 01 non insulated

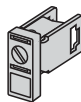

Jumper
X 222 066 01

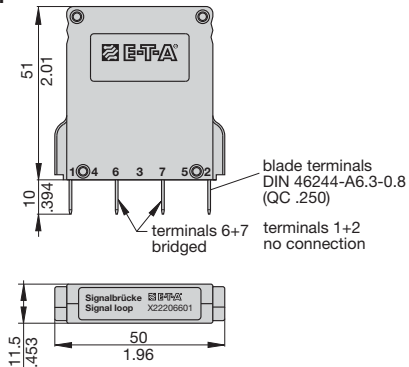

Retaining clip for SSRPC E-1048-7..
recommended for fitting the devices
Y 300 581 11

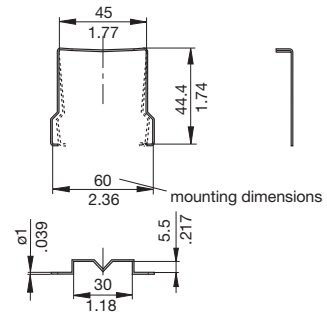

Labels

marking area 6 x 10 mm
(packing unit 10 pcs = 1 strip)
part. no. Y 307 942 61

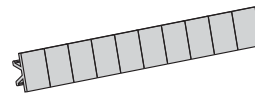

Accessories for E-1048-7..

Single mounting sockets

(up to 16 A max. load)

17-P10-Si

17-P70-Si

(retaining clip Y 300 581 11 available on request)

(with adapter)

17-P10-Si-20025

17-P70-Si-20025

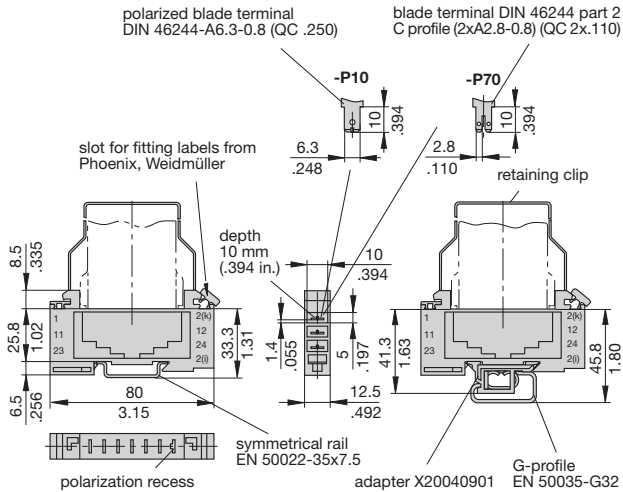

Busbar (10-way) (supplied as a complete package)

for type 17 socket

(for max. 100 A continuous load),

more positions available on request

X 211 157 01 with terminal

X 211 157 02 without terminal

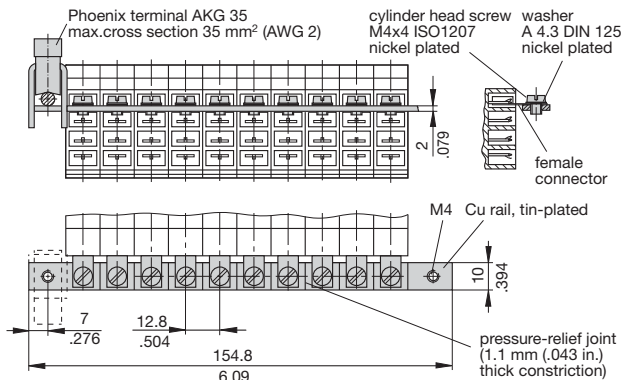

Insulating sleeving for busbar (10-way)

Y 303 824 01

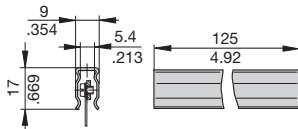

2-way mounting socket

23-P10-Si

(retaining clip Y 300 581 03 available on request)

6-way mounting socket

63-P10-Si

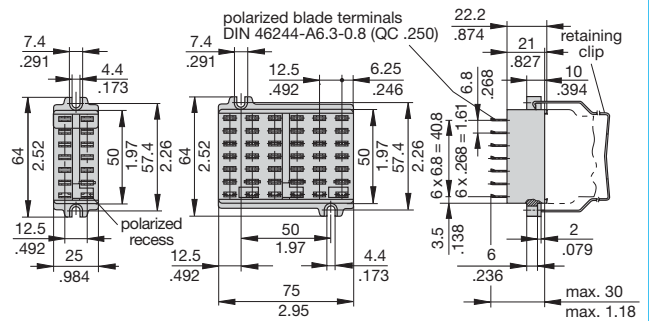

Connector bus links -P10

X 210 588 01/ 1.5 mm², (AWG 16), brown (up to 13 A max. load)

X 210 588 02/ 2.5 mm², (AWG 14), black (up to 20 A max. load)

X 210 588 03/ 2.5 mm², (AWG 14), red (up to 20 A max. load)

X 210 588 04/ 2.5 mm², (AWG 14), blue (up to 20 A max. load)

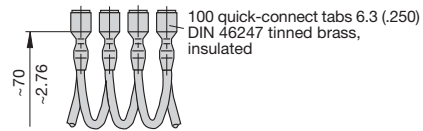

2 mounting clips

Y 300 504 02

Installation drawing with mounting clips Y 300 504 02

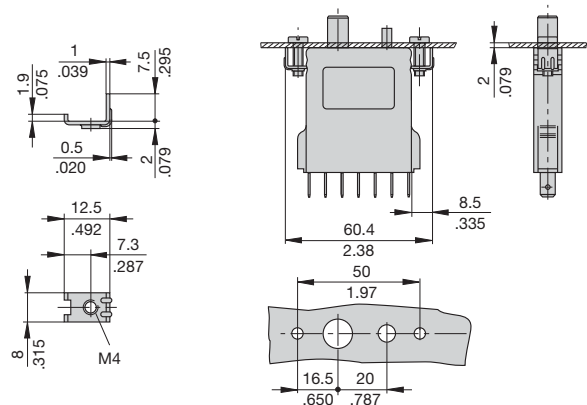

Pin selection 17-P10-Si, fitted with E-1048-7..

E-1048-7..	17-P10-Si	
LINE + (2)	(2) [2(k)]	
GND (5)	(5) [12]	
F 7 (7)	(7) [24]	
	(3) [2(i)]	
F 6 (6)	(6) [23]	
IN+ (4)	(4) [11]	
LOAD (1)	(1) [1]	

This is a metric design and millimeter dimensions take precedence ($\frac{\text{mm}}{\text{inch}}$)

All dimensions without tolerances are for reference only. In the interest of improved design, performance and cost effectiveness the right to make changes in these specifications without notice is reserved. Product markings may not be exactly as the ordering codes. Errors and omissions excepted.