

Description

Electronic circuit protector type ESX10-T is designed to ensure **selective** disconnection of DC 24 V load systems.

DC 24 V power supplies, which are widely used in industry today, will shut down the output in the event of an overload with the result that one faulty load in the system can lead to complete disconnection of all loads. As well as an unidentified failure this also means stoppage of the whole system.

Through **selective** disconnection the ESX10-T responds much faster to overload or short circuit conditions than the switch-mode power supply. This is achieved by active current limitation. The ESX10-T limits the highest possible current to 1.3 to 1.8 times the selected rated current of the circuit protector. Thus it is possible to switch on **capacitive loads of up to 20,000 µF**, but they are disconnected only in the event of an overload or short circuit.

For optimal alignment with the characteristics of the application the current rating of the ESX10-T can be selected in fixed values from 0.5 A...12 A. Failure and status indication are provided by a multicolour LED and an integral short-circuit-proof status output or a potential-free signal contact. Remote operation is possible by means of a remote reset signal or a remote ON/OFF control signal. The manual ON/OFF button allows separate actuation of individual load circuits.

The ESX10-T, with a width of only 12.5 mm, can be snapped onto symmetrical rails ensuring ease of installation and saving space in control cabinets.

Upon detection of overload or short circuit in the load circuit, the MOSFET of the load output will be blocked to interrupt the current flow. The load circuit can be re-activated via the remote electronic reset input, control input or manually by means of the ON/OFF button.

Features

- Selective load protection, electronic trip characteristics.
- Active current limitation for safe connection of capacitive loads up to 20,000 µF and on overload/short circuit.
- Current ratings 0.5 A...12 A.
- Reliable overload disconnection with $1.1 \times I_N$ plus, even with long load lines or small cable cross sections (see table 3).
- Manual ON/OFF button (S1).
- Control input IN+ for remote ON/OFF signal (option).
- Electronic reset input RE (option).
- Clear status and failure indication through LED, status output SF or Si contact F.
- Integral fail-safe element adjusted to current rating.
- Width per unit only 12.5 mm.
- Rail mounting
- Ease of wiring through busbar LINE+ and 0 V as well as signal bars and bridges.

Approvals

| Authority | Voltage rating | Current ratings |
|--|----------------|-----------------|
| UL 2367 | DC 24 V | 0.5...12 A |
| UL 1604 (class I, div. 2, group A, B, C, D) | DC 24 V | 0.5...12 A |
| UL 508 / cUL 508 | DC 24 V | 0.5...12 A |



ESX10-T

Technical data (T_{ambient} = 25 °C, operating voltage U_S = DC 24 V)

Operating data

| | |
|----------------------------------|---|
| Operating voltage U _S | DC 24 V (18...32 V) |
| Current rating I _N | fixed current ratings: 0.5, 1 A, 2 A, 3 A, 4 A, 6 A, 8 A, 10 A, 12 A |
| Closed current I ₀ | ON condition: typically 20...30 mA depending on signal output |
| Status indication by means of | <ul style="list-style-type: none"> ● multicolour LED: <ul style="list-style-type: none"> GREEN: unit is ON, power-MOSFET is switched on <ul style="list-style-type: none"> - status output SF ON, supplies + DC 24 V ORANGE: in the event of overload or short circuit until electronic disconnection RED: <ul style="list-style-type: none"> - unit electronically disconnected - load circuit/Power-MOSFET OFF OFF: <ul style="list-style-type: none"> - manually switched off (S1 = OFF) or device is dead - undervoltage (U_S < 8 V) - after switch-on till the end of the delay period ● status output SF (option) ● potential-free signal contact F (option) ● ON/OFF/ condition of switch S1 |

Load circuit

| | |
|--|---|
| Load output | Power-MOSFET switching output (high side switch) |
| Overload disconnection | typically $1.1 \times I_N$ ($1.05...1.35 \times I_N$) |
| Short-circuit current I _K | active current limitation (see table 1) |
| Trip time for electronic disconnection | see time/current characteristics typically 3 s at I _{Load} > $1.1 \times I_N$ typically 3 s...100 ms at I _{Load} > $1.8 \times I_N$ (or $1.5 \times I_N/1.3 \times I_N$) |
| Temperature disconnection | internal temperature monitoring with electronic disconnection |
| Low voltage monitoring load output | with hysteresis, no reset required load "OFF" at U _S < 8 V |
| Starting delay t _{start} | typically 0.5 sec after every switch-on and after applying U _S |
| Disconnection of load circuit | electronic disconnection |
| Free-wheeling circuit | external free-wheeling diode recommended with inductive load |
| Several load outputs must not be connected in parallel | |

Technical data ($T_{\text{ambient}} = 25^{\circ}\text{C}$, operating voltage $U_S = \text{DC } 24 \text{ V}$)

| | |
|----------------------------------|--|
| Status output SF | ESX10-TB-114/-124/ |
| Electrical data | plus-switching signal output, connects U_S to terminal 12 of module 17 plus nominal data: DC 24 V / max. 0.2 A (short circuit proof) status output is internally connected to GND with a 10 kOhm resistor |
| Status OUT | ESX10-TB-114/-124 (signal status OUT), at $U_S = +24 \text{ V}$ $+24 \text{ V} = \text{S1}$ is ON, load output connected through $0 \text{ V} = \text{S1}$ is ON, load output blocked and/or switch S1 is OFF red LED lighted |
| OFF condition | 0 V level at status output when: <ul style="list-style-type: none"> switch S1 is in ON position, but device is still in switch-on delay switch S1 is OFF, or control signal OFF, device is switched off no operating voltage U_S |
| Signal output F | ESX10-TB-101/-102 |
| Electrical data | potential-free signal contact max. DC 30 V/0.5 A, min. 10 V/10 mA |
| ON condition LED green | voltage U_S applied, switch S1 is in ON position no overload, no short circuit |
| OFF condition LED off | <ul style="list-style-type: none"> device switched off (switch S1 is in OFF position) no voltage U_S applied |
| Fault condition LED orange | overload condition $> 1.1 \times I_N$ up to electronic disconnection |
| Fault condition LED red | electronic disconnection upon overload or short circuit device switched off with control signal (switch S1 is in ON position) |
| ESX10-TB-101 | single signal, make contact contact SC/SO-SI open |
| ESX10-TB-102 | single signal, break contact contact SC/SO-SI closed |
| Fault | signal output fault conditions: <ul style="list-style-type: none"> no operating voltage U_S ON/OFF switch S1 is in OFF position red LED lighted (electronic disconnection) |
| Reset input RE | ESX10-TB-124/-127 |
| Electrical data | voltage: max. +DC 32 V high $> \text{DC } 8 \text{ V} \leq \text{DC } 32 \text{ V}$ low $\leq \text{DC } 3 \text{ V} > 0 \text{ V}$ power consumption typically 2.6 mA (+DC 24 V) min. pulse duration typically 10 ms |
| Reset signal RE (terminal 22) | The electronically blocked ESX10-TB-124/-127 may remotely be reset via an external momentary switch due to the falling edge of a +24 V pulse. A common reset signal can be applied to several devices simultaneously. Switched on devices remain unaffected. |
| Control input IN+ | ESX10-TB-114 |
| Electrical data | see reset input RE |
| Control signal IN+ (terminal 21) | +24V level (HIGH): device will be switched on by a remote ON/OFF signal 0 V level (LOW): device will be switched off by a remote ON/OFF signal |
| Switch S1 ON/OFF | unit can only be switched on with S1 if a HIGH level is applied to IN+ |

Technical data ($T_{\text{ambient}} = 25^{\circ}\text{C}$, operating voltage $U_S = \text{DC } 24 \text{ V}$)

| | |
|---|--|
| General data | |
| Fail-safe element: | backup fuse for ESX10-T <u>not required</u> because of the integral redundant fail-safe element |
| Terminals | LINE+ / LOAD+ / 0V |
| screw terminals | M4 |
| max. cable cross section | |
| flexible with wire end ferrule w/wo plastic sleeve | 0.5 - 10 mm ² |
| multi-lead connection (2 identical cables) | |
| rigid/flexible | 0.5 - 4 mm ² |
| flexible with wire end ferrule without plastic sleeve | 0.5 - 2.5 mm ² |
| flexible with TWIN wire end ferrule with plastic sleeve | 0.5 - 6 mm ² |
| wire stripping length | 10 mm |
| tightening torque (EN 60934) | 1.5 - 1.8 Nm |
| Terminals | aux. contacts |
| screw terminals | M3 |
| max. cable cross section | |
| flexible with wire end ferrule w/wo plastic sleeve | 0.25 - 2.5 mm ² |
| wire stripping length | 8 mm |
| tightening torque (EN 60934) | 0.5 Nm |
| Housing material | moulded |
| Mounting | symmetrical rail to EN 50022-35x7.5 |
| Ambient temperature | 0...+50 °C (without condensation, see EN 60204-1) |
| Storage temperature | -20...+70 °C |
| Humidity | 96 hrs/95 % RH/40 °C to IEC 60068-2-78, test Cab. climate class 3K3 to EN 60721 |
| Vibration | 3 g, test to IEC 60068-2-6 test Fc |
| Degree of protection | housing: IP20 DIN 40050 terminals: IP20 DIN 40050 |
| EMC (EMC directive, CE logo) | emission: EN 61000-6-3 susceptibility: EN 61000-6-2 |
| Insulation co-ordination (IEC 60934) | 0.5 kV/2 pollution degree 2 re-inforced insulation in operating area |
| dielectric strength | max. DC 32 V (load circuit) |
| Insulation resistance (OFF condition) | n/a, only electronic disconnection |
| Approvals | UL 2367, File E306740, Solid State Overcurrent Protectors UL 1604, File E320024, (class I, division 2, groups A, B, C, D) UL 508 / cUL 508, File E322549 CE logo |
| Dimensions (W x H x D) | 12.5 x 80 x 83 mm |
| Mass | approx. 65 g |

Table 1: voltage drop, current limitation, max. load current

| current rating I_N | typically voltage drop U_{ON} at I_N | active current limitation (typically) | max. load current at 100 % ON duty $T_{\text{ambient}} = 40^{\circ}\text{C}$ | $T_{\text{ambient}} = 50^{\circ}\text{C}$ |
|----------------------|--|---------------------------------------|--|---|
| 0.5 A | 70 mV | $1.8 \times I_N$ | 0.5 A | 0.5 A |
| 1 A | 80 mV | $1.8 \times I_N$ | 1 A | 1 A |
| 2 A | 130 mV | $1.8 \times I_N$ | 2 A | 2 A |
| 3 A | 80 mV | $1.8 \times I_N$ | 3 A | 3 A |
| 4 A | 100 mV | $1.8 \times I_N$ | 4 A | 4 A |
| 6 A | 130 mV | $1.8 \times I_N$ | 6 A | 5 A |
| 8 A | 120 mV | $1.5 \times I_N$ | 8 A | 7 A |
| 10 A | 150 mV | $1.5 \times I_N$ | 10 A | 9 A |
| 12 A | 180 mV | $1.3 \times I_N$ | 12 A | 10.8 A |

Attention: when mounted side-by-side without convection the ESX10-T should not carry more than 80 % of its rated load with 100 % ON duty due to thermal effects.

Ordering information

Type No.

ESX10 Electronic Circuit Protector, with current limitation

Mounting and design

TA rail mounting, without signal contact

TB rail mounting, with signal contact and slot for busbars and jumpers

Version

1 standard, without physical isolation in the event of a failure

Signal input

0 without signal input

1 with control input IN+, only ESX10-T-114

2 with reset input RE, only ESX10-T-124, ESX10-T-127

Signal outputs

0 without signal output

1 signal contact N/O

2 signal contact N/C

4 status output SF

(only ESX10-T-114, ESX10-T-124)

7 inverse status output SF

(only ESX10-T-127)

Operating voltage

DC 24 V rated voltage DC 24 V

Current rating

0.5 A

1 A

2 A

3 A

4 A

6 A

8 A

10 A

12 A

ESX10 - TA 1 0 0 - DC 24 V - 6 A ordering example

Description of ESX10-T signal inputs and outputs (wiring diagrams) see next page.

Please note:

- The user should ensure that the cable cross sections of the relevant load circuit are suitable for the current rating of the ESX10-T used.
- Automatic start-up of machinery after shut down must be prevented (Machinery Directive 98/37/EG and EN 60204-1). In the event of a short circuit or overload the load circuit will be disconnected electronically by the ESX10-T.

Schematic diagram ESX10-TB-124 (Example)

ESX10-TB-124-...

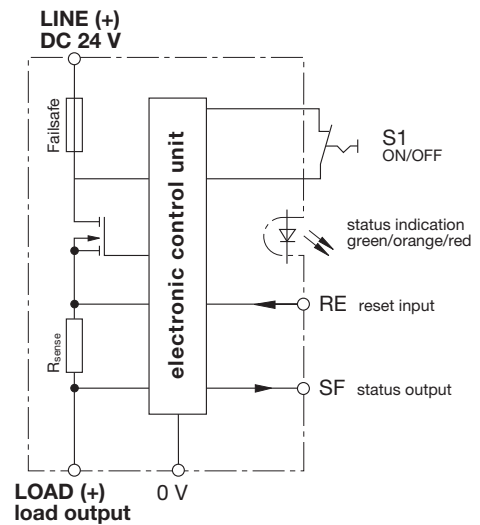

Terminal wiring diagram ESX10-TB-124 (Example)

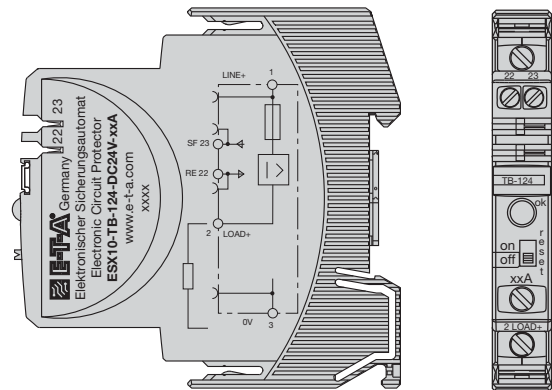
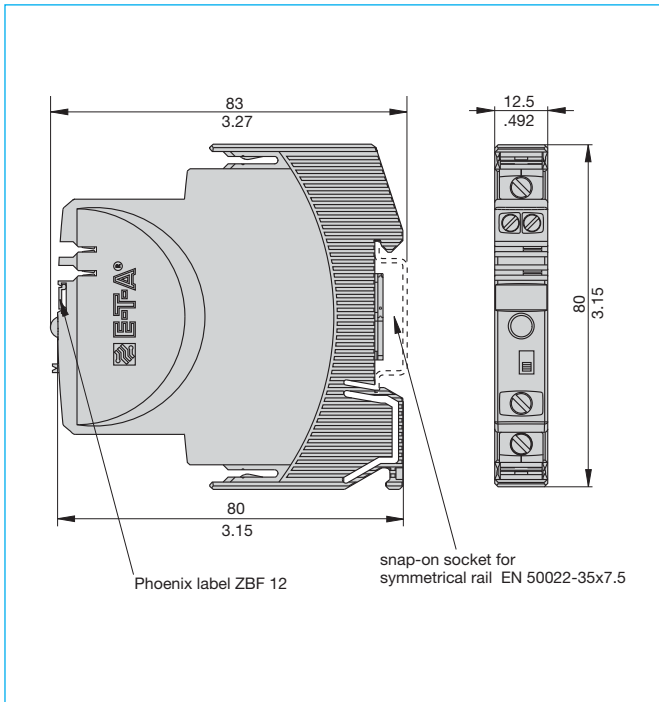

Table 2: ESX10-T - product version

| Version | | Signal input | | | Signal output | | | | |
|----------|------|--------------|--|------------------------------|----------------------------------|---|---|------------------|-----------------------------------|
| | | | | | Signal output F (Signal contact) | | | Status output SF | |
| ESX10-.. | | without | Control input ON/OFF +24 V Control IN+ | Reset input +24 V ↓ RE | without | single signal N/O (normally open NO) | single signal N/C (normally closed NC) | without | Status output SF +24 V = OK |
| -TA | -100 | x | | | x | | | x | |
| -TB | -101 | x | | | | x | | x | |
| -TB | -102 | x | | | | | x | x | |
| -TB | -114 | | x | | | | | | x |
| -TB | -124 | | | x | x | | | | x |
| -TB | -127 | | | x | x | | | | x |

Dimensions



Information on UL approvals

UL1604
File E320024

Operating Temperature Code T5

- This equipment is suitable for use in Class I, Division 2, Groups A, B, C and D or non-hazardous locations only

WARNING:

- Exposure to some chemicals may degrade the sealing properties of materials used in the following device: relay

Sealant Material:

Generic Name: Modified diglycidyl ether of bisphenol A
Supplier: Fine Polymers Corporation
Type: Epi Fine 4616L-160PK

Casing Material:

Generic Name: Liquid Crystal Polymer
Supplier: Sumitomo Chemical
Type: E4008, E4009, or E6008

RECOMMENDATION:

- Periodically inspect the device named above for any degradation of properties and replace if degradation is found

WARNING – EXPLOSION HAZARD:

- Do not disconnect equipment unless power has been removed or the area is known to be non-hazardous
- Substitution of any components may impair suitability for Class I, Division 2

UL2367

Non-hazardous use - UL File E306740

UL 508 / cUL 508
File E322549

Class 2

Meets requirement for Class 2 current limitation
(ESX10-T...-0.5 A / 1 A / 2 A / 3 A)

Instruction leaflet



Electronic Circuit Protector ESX10-T

UL1604

This device is suitable for use in Class I, Div 2, Groups A, B, C, D;
TC T5; UL File E320024

Warnings:

1. Remove power before disconnecting device.
2. Components substitutions may impair suitability of Class I, Div 2.
3. Chemical exposure may degrade internal relay's sealing property.

UL2367

Non-hazardous use - UL File E306740

Refer to data sheet / installation guidelines for installation
and safety instructions.

E-T-A Elektrotechnische Apparate GmbH
Industriestraße 2-8 · 90518 ALTENDORF
DEUTSCHLAND
Tel. +49 (09187) 10-0 · Fax +49 (09187) 10-397
E-Mail: info@e-t-a.de · www.e-t-a.com

ESX10-T Signal inputs / outputs (wiring diagram)

ESX10-TA-100
without signal input/output

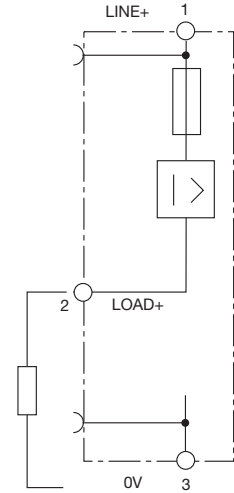

ESX10-TB-101
without signal input
with signal output F
(single signal, N/O)

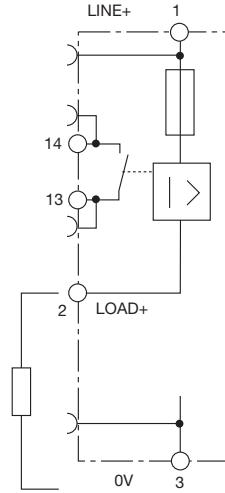

operating condition: 13-14 closed
fault condition: 13-14 open

ESX10-TB-102
without signal input
with signal output F
(single signal, N/C)

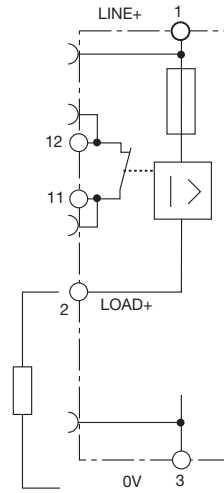

operating condition: 11-12 open
fault condition: 11-12 closed

ESX10-TB-114
with control input IN+
(+DC 24 V)
with status output SF
(+24 V = load output ON)

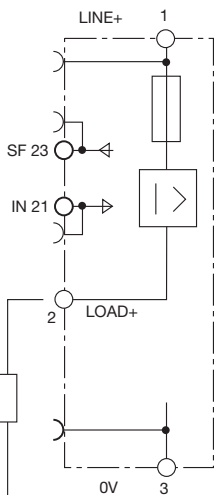

operating condition: SF +24 V = OK
fault condition: SF 0 V

ESX10-TB-124
with reset input RE
(+DC 24 V ↓)
with status output SF
(+24 V = load output ON)

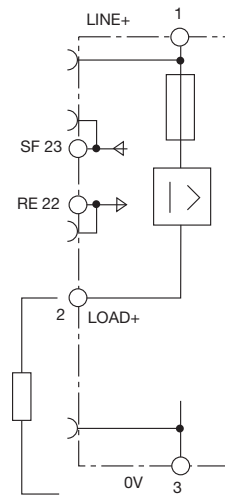

operating condition: SF +24 V = OK
fault condition: SF 0 V

ESX10-TB-127
with reset input RE
(+DC 24 V ↓)
with inverse status output SF
(0 V = load output ON)

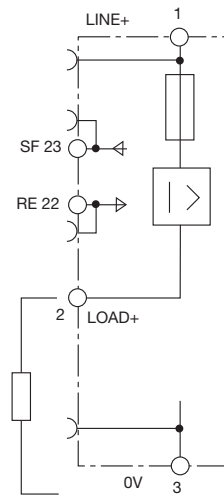

operating condition: SF 0 V = OK
fault condition: SF +24 V

Time/Current characteristic curve ($T_A = 25\text{ }^\circ\text{C}$)

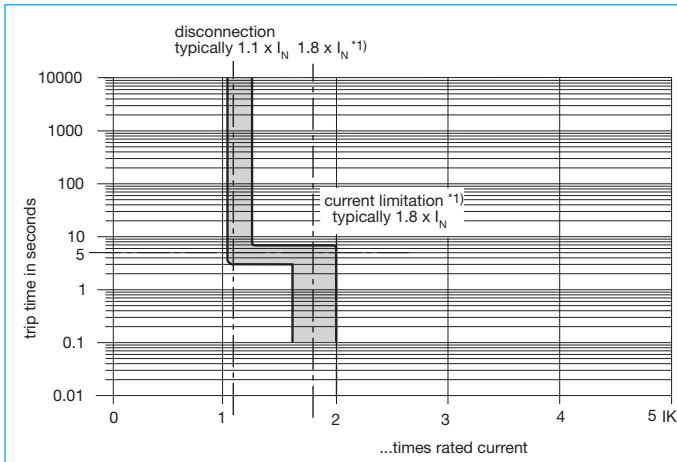

- The trip time is typically 3 s in the range between 1.1 and 1.8 x I_N^{*1}.
- Electronic current limitation occurs at typically 1.8 x I_N^{*1} which means that under all overload conditions (independent of the power supply and the resistance of the load circuit) the max. overload before disconnection will not exceed 1.8 x I_N^{*1} times the current rating. Trip time is between 100 ms and 3 sec (depending on overload or at short circuit).
- Without this current limitation a considerably higher overload current would flow in the event of an overload or short circuit.

*1) current limitation typically 1.8 x I_N times rated current at I_N = 0.5 A...6 A
 current limitation typically 1.5 x I_N times rated current at I_N = 8 A or 10 A
 current limitation typically 1.3 x I_N times rated current at I_N = 12 A

Table 3: Reliable trip of ESX10-T

| Reliable trip of ESX10-T with different cable lengths and cross sections | | | |
|--|---|--|-------------|
| Resistivity of copper $\rho_0 =$ | | 0.0178 (Ohm x mm ²) / m | |
| $U_S = \text{DC } 19.2 \text{ V}$ (= 80 % of 24 V) | | voltage drop of ESX10-T and tolerance of trip point (typically 1.1 x I _N = 1.05 ... 1.35 x I _N) have been taken into account. | |
| ESX10-T-selected rating I _N (in A) | → | 3 | 6 |
| e. g. trip current I _{ab} = 1.25 x I _N (in A) | → | 3.75 | 7.5 |
| R_{max} in Ohm = (U _S / I _{ab}) - 0.050 | → | 5.07 | 2.51 |

5

The ESX10-T reliably trips from 0 Ohm to max. circuitry resistance R_{max}

| Cable cross section A in mm ² | 0.14 | 0.25 | 0.34 | 0.5 | 0.75 | 1 | 1.5 |
|---|--|-------|-------|-------|-------|------|------|
| cable length L in meter (= single length) | cable resistance in Ohm = (R ₀ x 2 x L) / A | | | | | | |
| | ↓ | ↓ | ↓ | ↓ | ↓ | ↓ | ↓ |
| 5 | 1.27 | 0.71 | 0.52 | 0.36 | 0.24 | 0.18 | 0.12 |
| 10 | 2.54 | 1.42 | 1.05 | 0.71 | 0.47 | 0.36 | 0.24 |
| 15 | 3.81 | 2.14 | 1.57 | 1.07 | 0.71 | 0.53 | 0.36 |
| 20 | 5.09 | 2.85 | 2.09 | 1.42 | 0.95 | 0.71 | 0.47 |
| 25 | 6.36 | 3.56 | 2.62 | 1.78 | 1.19 | 0.89 | 0.59 |
| 30 | 7.63 | 4.27 | 3.14 | 2.14 | 1.42 | 1.07 | 0.71 |
| 35 | 8.90 | 4.98 | 3.66 | 2.49 | 1.66 | 1.25 | 0.83 |
| 40 | 10.17 | 5.70 | 4.19 | 2.85 | 1.90 | 1.42 | 0.95 |
| 45 | 11.44 | 6.41 | 4.71 | 3.20 | 2.14 | 1.60 | 1.07 |
| 50 | 12.71 | 7.12 | 5.24 | 3.56 | 2.37 | 1.78 | 1.19 |
| 75 | 19.07 | 10.68 | 7.85 | 5.34 | 3.56 | 2.67 | 1.78 |
| 100 | 25.34 | 14.24 | 10.47 | 7.12 | 4.75 | 3.56 | 2.37 |
| 125 | 31.79 | 17.80 | 13.09 | 8.90 | 5.93 | 4.45 | 2.97 |
| 150 | 38.14 | 21.36 | 15.71 | 10.68 | 7.12 | 5.34 | 3.56 |
| 175 | 44.50 | 24.92 | 18.32 | 12.46 | 8.31 | 6.23 | 4.15 |
| 200 | 50.86 | 28.48 | 20.94 | 14.24 | 9.49 | 7.12 | 4.75 |
| 225 | 57.21 | 32.04 | 23.56 | 16.02 | 10.68 | 8.01 | 5.34 |
| 250 | 63.57 | 35.60 | 26.18 | 17.80 | 11.87 | 8.90 | 5.93 |

- Example 1:** max. length at 1.5 mm² and 3 A **214 m** →
- Example 2:** max. length at 1.5 mm² and 6 A **106 m** →
- Example 3:** mixed wiring: R1 = 40 m in 1.5 mm² and R2 = 5 m in 0.25 mm²:
 (Control cabinet – sensor/actuator level) R1 = 0.95 Ohm, R2 = 0.71 Ohm **Total (R1 + R2) = 1.66 Ohm**

Mounting examples for ESX10-T

The ESX10-T features an integral power distribution system.

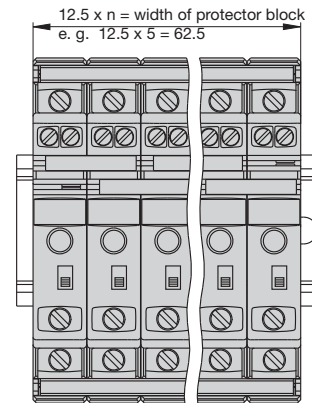
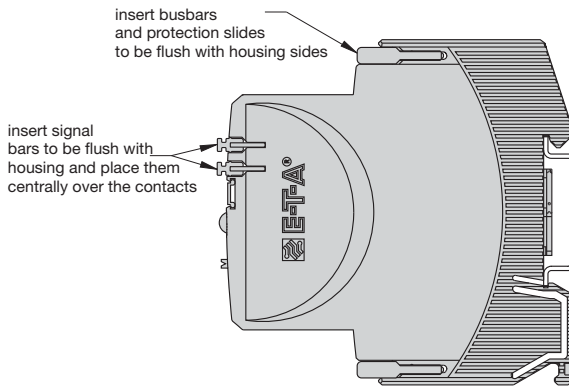
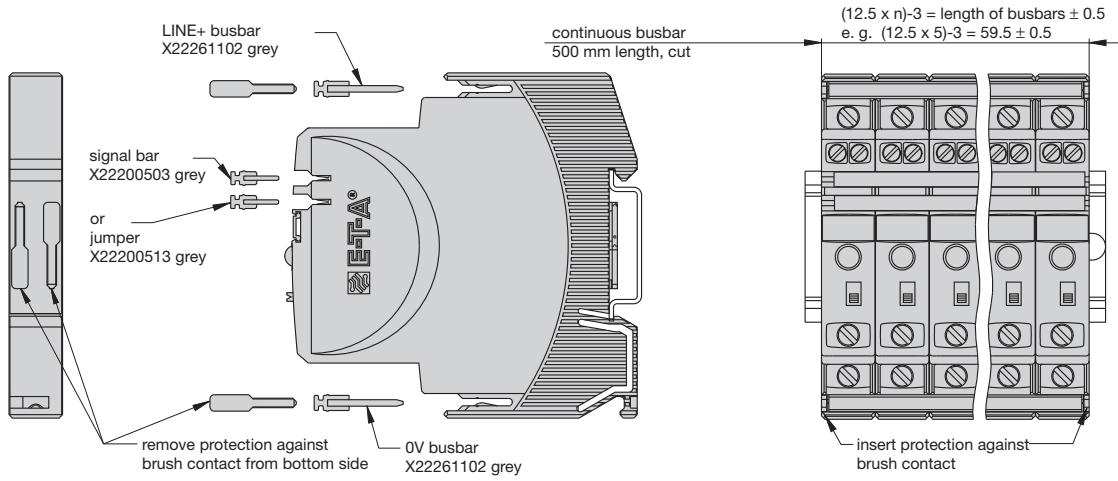

5 ESX10-TB
with busbars
and jumpers

5 ESX10-TA
with busbars

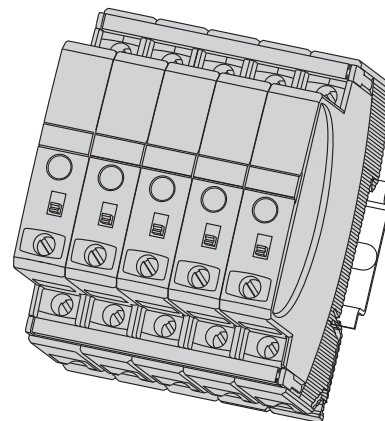
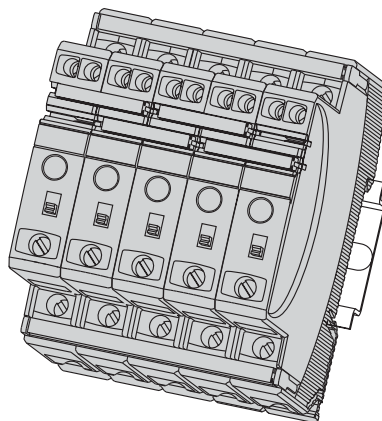

Mounting procedure:

Before wiring insert busbars into protector block.

Connection diagrams and application examples ESX10-T

ESX10-TB-102

Single signalling with common line entry

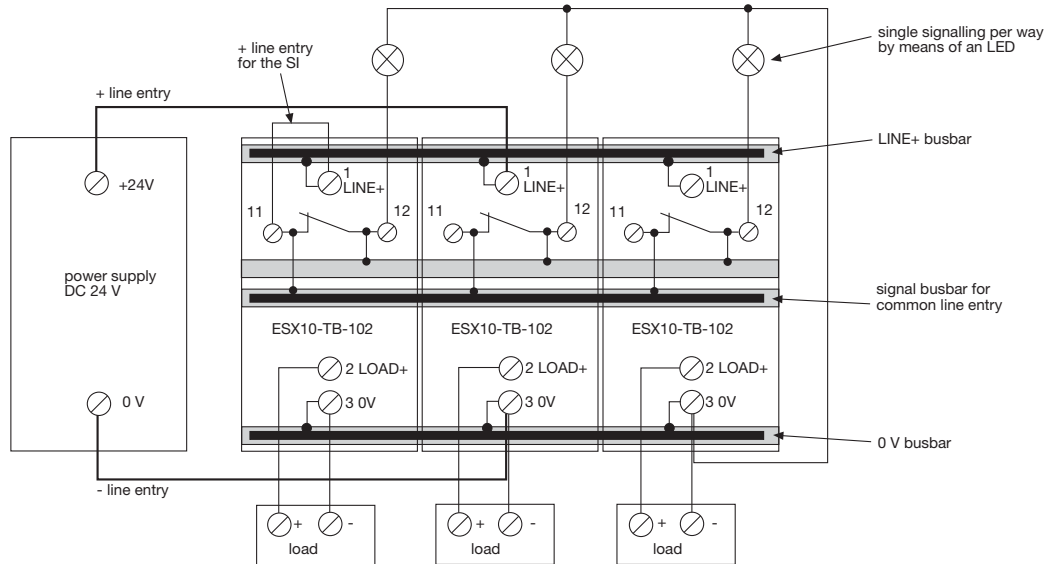

ESX10-TB-124

Single signalling with common reset

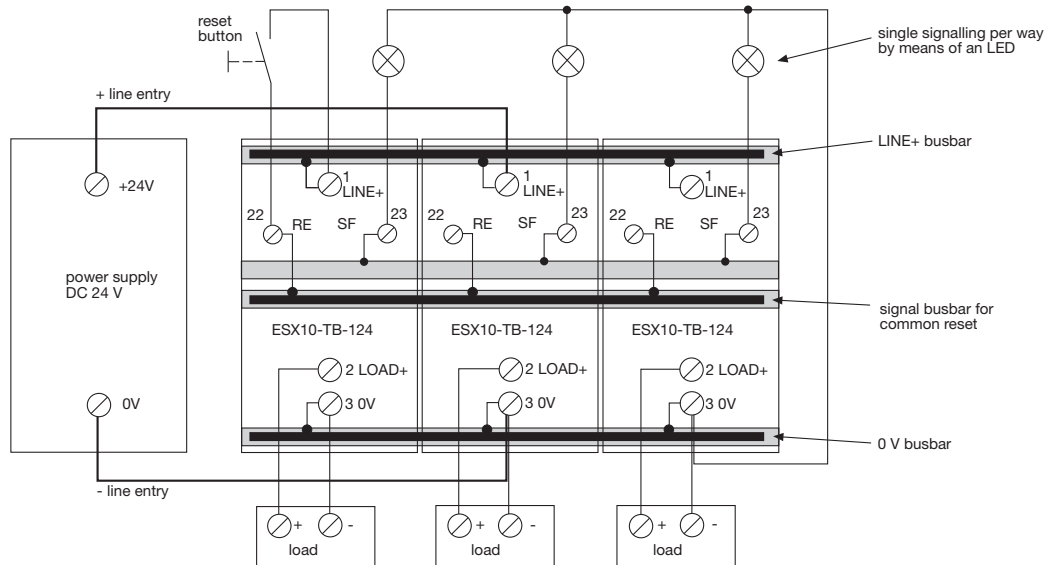

Description

The ESX10-T features an integral power distribution system. The following wiring modes are possible with various pluggable current and signal busbars:

- LINE +(DC 24 V)
- 0 V
- **Caution:** The electronic devices ESX10-T require a 0 V connection
- signal contacts
- reset inputs

Busbars for LINE+ and 0 V

max. load with one line entry (recommended: centre line entry) I_{max} 50 A
 max. load with two line entries I_{max} 63 A
 grey insulation, length: 500 m
X 222 611 02

Signal busbars for signal contacts and reset inputs

max. load with one line entry I_{max} 1 A
 with one series connection of signal contacts I_{max} 0.5 A
 grey insulation, length: 500 m
X 222 005 03

Jumpers for signal contacts

grey insulation, length: 21 m
X 222 005 13
 packing unit: 10 pcs

Insulated wire bridge

optional as jumper for ESX10-TB-101
 for group signalisation (series connection)
X 222 984 01
 packing unit: 10 pcs

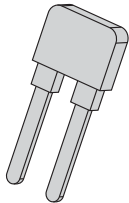

Busbars for LINE+ and 0 V

grey insulation
 max. number of plug-on operations 10
X 222 611 34, (3-unit-block ESX10-T), length: 34.5 mm
X 222 611 47, (4-unit-block ESX10-T), length: 47 mm
X 222 611 59, (5-unit-block ESX10-T), length: 59.5 mm
 packing unit: 10 pcs

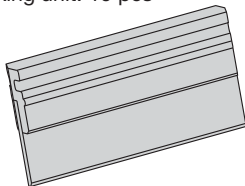

All dimensions without tolerances are for reference only. In the interest of improved design, performance and cost effectiveness the right to make changes in these specifications without notice is reserved. Product markings may not be exactly as the ordering codes. Errors and omissions excepted.