

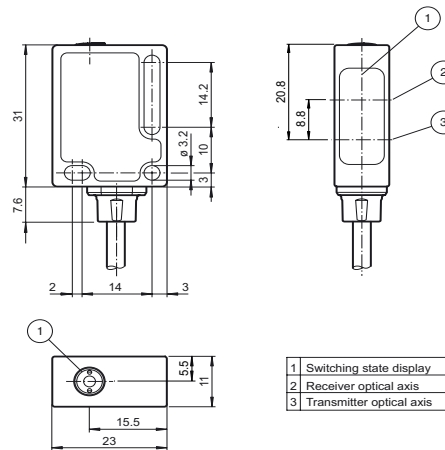

**Dimensions**



**Model Number**

**ML8-8-HGU-50-RT/59/102/115/162**

Convergent mode sensor  
with 2 m fixed cable

**Features**

- Detection of circuit boards
- Background interference suppression
- Very small black-white difference
- Plug and Play
- Not sensitive to ambient light, even with switched energy saving lamps

**Accessories**

**OMH-ML7-01**  
Mounting aid

**OMH-ML7-02**  
Mounting aid

**OMH-ML7-03**  
Mounting aid

**Electrical connection**

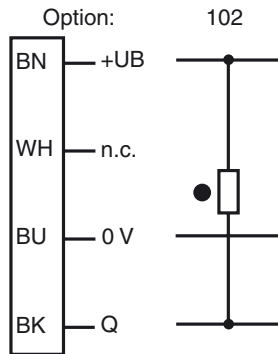

○ = Light on  
● = Dark on

Release date: 2008-09-30 10:14 Date of issue: 2008-09-30 204319\_ENG.xml

Additional accessories can be found in the Internet.

Subject to modifications without notice

Pepperl+Fuchs Group  
www.pepperl-fuchs.com

USA: +1 330 486 0001  
fa-info@us.pepperl-fuchs.com

Germany: +49 621 776-4411  
fa-info@de.pepperl-fuchs.com

Copyright Pepperl+Fuchs  
Singapore: +65 6779 9091  
fa-info@sg.pepperl-fuchs.com

**Technical data**

**General specifications**

Detection range	25 ... 50 mm
Light source	LED, red
Approvals	CE, cULus Listed 57M3 (Only in association with UL Class 2 power supply; Type 1 enclosure)
Reference target	standard black, 100 mm x 100 mm
Light type	red, modulated light
Diameter of the light spot	approx. 4 mm x 35 mm at 50 mm
Angle of divergence	Emitter 1.5° vertical 35° horizontal
Ambient light limit	EN 60947-5-2

**Indicators/operating means**

Function display	2 LEDs yellow, light up in case of detection
------------------	--

**Electrical specifications**

Operating voltage	$U_B$	10 ... 30 V DC , class 2
Ripple		max. 10 %
No-load supply current	$I_0$	< 20 mA

**Output**

Switching type	dark ON	
Signal output	1 NPN output, short-circuit proof, protected from reverse polarity, open collector	
Switching voltage	max. 30 V DC	
Switching current	max. 100 mA	
Voltage drop	$U_d$	≤ 1.5 V DC
Response time		1 ms

**Standard conformity**

Standards	EN 60947-5-2
Standards 2	UL 508

**Ambient conditions**

Ambient temperature	-20 ... 60 °C (253 ... 333 K)
Storage temperature	-40 ... 70 °C (233 ... 343 K)

**Mechanical specifications**

Protection degree	IP65 / IP67
Connection	fixed cable 2 m
Material	
Housing	PC (Makrolon, glass-fibre-reinforced)
Optical face	PMMA
Mass	approx. 50 g

**Curves/Diagrams**

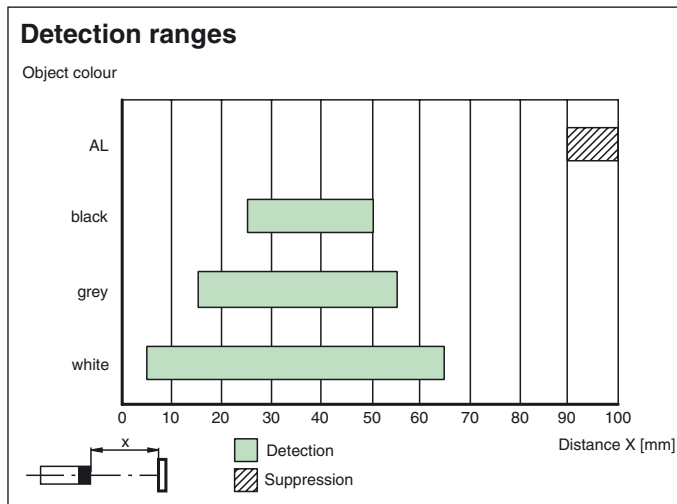

Release date: 2008-09-30 10:14 Date of issue: 2008-09-30 204319\_ENG.xml