



Model number

INX360D-F99-I2E2-7M

Features

- Measuring range 0 ... 360°
- Analog output 4 mA ... 20 mA
- Evaluation limits can be taught-in
- 2 programmable switch outputs
- High shock resistance
- e1-Type approval
- Raised EMC resistance 100 V/m

Technical Data

General specifications

Type	Inclination sensor, 1-axis
Measurement range	0 ... 360 °
Absolute accuracy	≤ ± 0.5 °
Response delay	≤ 20 ms
Resolution	≤ 0.1 °
Repeat accuracy	≤ ± 0.1 °
Temperature influence	≤ 0.027 °/K

Indicators/operating means

Operating display	LED, green
TEACH-IN indication	2 LEDs yellow (switching status), flashing
Button	2 push-buttons (Switch points programming , Evaluation range programming)
Switching state	2 yellow LEDs: Switching status (each output)

Electrical specifications

Operating voltage U_B	10 ... 30 V DC
No-load supply current I_0	≤ 25 mA
Time delay before availability t_v	≤ 200 ms

Switching output

Output type	2 switch outputs PNP, NO , reverse polarity protected , short-circuit proof
Operating current I_L	≤ 100 mA
Voltage drop	≤ 3 V

Analog output

Output type	1 current output 4 ... 20 mA
Load resistor	0 ... 200 Ω at $U_B = 10 ... 18 V$ 0 ... 500 Ω at $U_B = 18 ... 30 V$

Ambient conditions

Ambient temperature	-40 ... 85 °C (-40 ... 185 °F)
Storage temperature	-40 ... 85 °C (-40 ... 185 °F)

Mechanical specifications

Connection type	7 m, PUR cable 5 x 0.5 mm ²
Housing material	PA
Protection degree	IP68 / IP69K
Mass	240 g

Compliance with standards and directives

Standard conformity	
Shock and impact resistance	100 g according to DIN EN 60068-2-27
Standards	EN 60947-5-2:2007 IEC 60947-5-2:2007

Approvals and certificates

CSA approval	cCSAus Listed, General Purpose, Class 2 Power Source
e1 Type approval	2006/28/EG

EMC Properties

Emitted interference and interference immunity in accordance with motor vehicle directive 2006/28/EG (e1 Type approval)

Interference immunity in accordance with

DIN ISO 11452-2: 100 V/m

Frequency band 20 MHz up to 2 GHz

Mains-borne interference in accordance with ISO 7637-2:

Pulse	1	2a	2b	3a	3b	4
Severity level	III	III	III	III	III	III
Failure criterion	C	A	C	A	A	C

EN 61000-4-2: CD: 8 kV / AD: 15 kV

Severity level II III

EN 61000-4-3: 30 V/m (80...2500 MHz)

Severity level IV

EN 61000-4-4: 2 kV

Severity level III

EN 61000-4-6: 10 V (0.01...80 MHz)

Severity level III

EN 55011: Klasse A

Dimensions

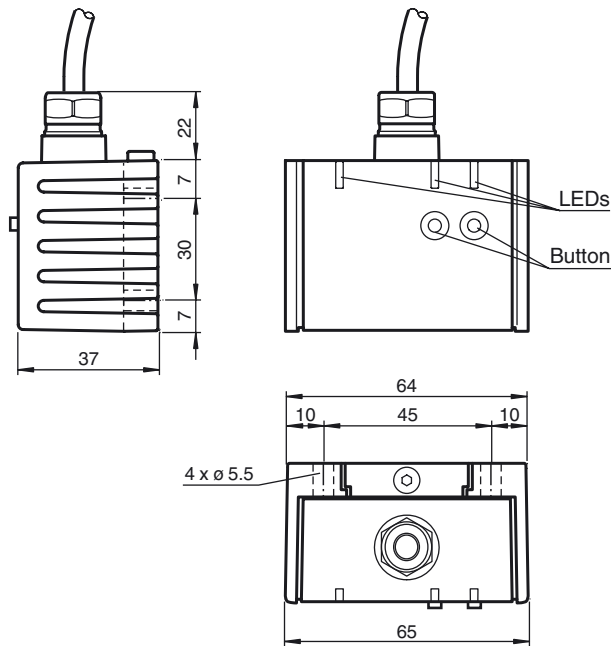

Electrical connection

Standard symbol/Connection:

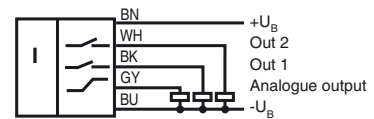

Sensor Orientation

In the default setting the zero position of the sensor is reached, when the electrical connection faces straight upwards.

- On request, all required mounting positions can be preset at the factory.
For example: X = 0 if the electrical connection points straight downwards.

X Orientation

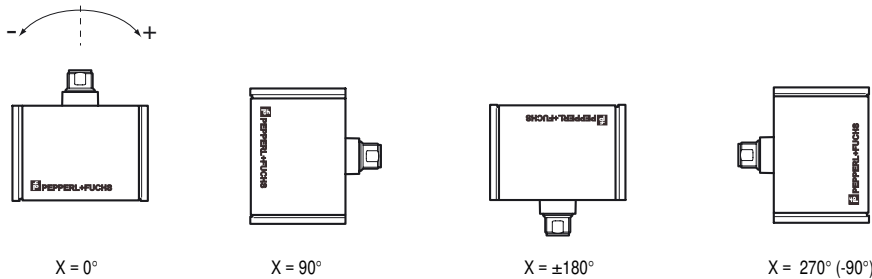

Mounting of the sensor

Inclination sensors from the -F99 series consist of a sensor module and accompanying cast aluminum housing. Select a flat surface with minimum dimensions of 70 mm x 50 mm to mount the sensor. Mount the sensor as follows:

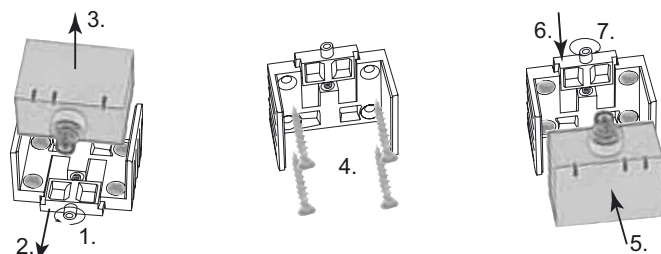

1. Loosen the central screw under the sensor connection.
 2. Slide back the clamping element until you are able to remove the sensor module from the housing.
 3. Remove the sensor module from the housing
 4. Position the housing at the required mounting location and secure using four countersunk screws. Make sure that the heads of the screws do not protrude.
 5. Place the sensor module in the housing.
 6. Slide the clamping element flush into the housing. Check that the sensor element is seated correctly.
 7. Finally tighten the central screw.
- The inclination sensor is now mounted correctly.

LED display

Release date: 2010-04-19 11:45 Date of edition: 2010-04-19 209308_ENG.xml

Displays dependent on the operating state	LED green: Power	LED yellow out 1	LED yellow out 2
Teach-in of switching points (output S1):	off	flashes	off
Teach-in of switching points (output S2):	off	off	flashes
Activate teach-in mode for analog limits:	off	flashes	flashes
Teach-in of analog limits	off	flashes	off
Normal operation	on	switchingstate	switchingstate
Reset to factory settings:			
2 s ... 10 s	off	flashes	flashes
> 10 s ... end of reset process	flashes	off	off
Followed by normal operation			
Undervoltage	flashes	off	off

Axis definition

The definition of the X-axis is shown on the sensor housing by means of an imprinted and labeled double arrow. The figure shows the clockwise direction of rotation.

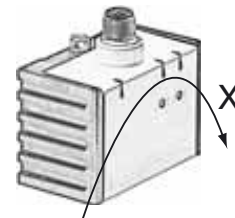

Teach-in of switching points (output S1)

1. Press key T1 > 2 s (see LED display)
2. Move sensor to switching position 1
3. Press key T1 briefly. LED "out 1" lights for 1.5 s as confirmation. Switching point 1 has been taught
4. Move sensor to switching position 2
5. Press key T1 briefly. LED "out 1" lights for 1.5 s as confirmation. Switching point 2 has been taught
6. Sensor returns to normal operation (see LED display)



If the switching points are taught in clockwise direction, the switching output between these switching points works as a NO contact. If the switching points are taught in anticlockwise direction, the switching output between these switching points works as a NC contact.

Teach-in of switching points (output S2)

Similar to the process for "Teach-in of switching points (output S1)", but with key T2 instead of key T1.

Teach-in of analog limits

1. Activate the teach-in mode for the analog limits by simultaneously pressing keys T1 and T2 until the green LED is extinguished and the two yellow LEDs flash. Then release the keys.
2. Press key T1 > 2 s (see LED display)
3. Move the sensor into the position of evaluation limit 4 mA
4. Press key T1 briefly. LED "out 1" lights for 1.5 s as confirmation. Evaluation limit 4 mA has been taught
5. Move the sensor into the position of evaluation limit 20 mA
6. Press key T1 briefly. LED "out 1" lights for 1.5 s as confirmation. Evaluation limit 20 mA has been taught
7. Sensor returns to normal operation (see LED display)



If the sensor inclination exceeds one of the analog limits, the last current value of the analog output is retained.

Resetting the sensor to factory settings

1. Press keys T1 and T2 > 10 s (see LED display)
2. The sensor has been reset when the green LED "Power" lights again after approx. 10 s.

Undervoltage detection

If the supply voltage falls below a value of approx. 7 V, all outputs and yellow LEDs are deactivated. The green "power" LED flashes rapidly. If the supply voltage falls below a value of approx. 8 V, the sensor continues with normal operation.