



Model number

INY360D-F99-2U2E2-5M

Features

- Measuring range 0 ... 360°
- Analog output 0 V ... 5 V
- Evaluation limits can be taught-in
- 2 programmable switch outputs
- High shock resistance
- e1-Type approval
- Raised EMC resistance 100 V/m

Technical Data

General specifications

Type	Inclination sensor, 2-axis
Measurement range	0 ... 360 °
Absolute accuracy	≤ ± 0.5 °
Response delay	≤ 25 ms
Resolution	≤ 0.1 °
Repeat accuracy	≤ ± 0.1 °
Temperature influence	≤ 0.027 °/K

Indicators/operating means

Operating display	LED, green
TEACH-IN indication	2 LEDs yellow (switching status), flashing
Button	2 push-buttons (Switch points programming , Evaluation range programming)
Switching state	2 yellow LEDs: Switching status (each output)

Electrical specifications

Operating voltage U_B	10 ... 30 V DC
No-load supply current I_0	≤ 25 mA
Time delay before availability t_v	≤ 200 ms

Switching output

Output type	2 switch outputs PNP, NO , reverse polarity protected , short-circuit proof
Operating current I_L	≤ 100 mA
Voltage drop	≤ 3 V

Analog output

Output type	2 voltage outputs 0 ... 5 V (one output for each axis)
Load resistor	≥ 1 kΩ

Ambient conditions

Ambient temperature	-40 ... 85 °C (-40 ... 185 °F)
Storage temperature	-40 ... 85 °C (-40 ... 185 °F)

Mechanical specifications

Connection type	5 m, PUR cable 7 x 0.5 mm ²
Housing material	PA
Protection degree	IP68 / IP69K
Mass	240 g

Compliance with standards and directives

Standard conformity	
Shock and impact resistance	100 g according to DIN EN 60068-2-27
Standards	EN 60947-5-2:2007 IEC 60947-5-2:2007

Approvals and certificates

CSA approval	cCSAus Listed, General Purpose, Class 2 Power Source
e1 Type approval	2006/28/EG

EMC Properties

Emitted interference and interference immunity in accordance with motor vehicle directive 2006/28/EG (e1 Type approval)

Interference immunity in accordance with

DIN ISO 11452-2: 100 V/m

Frequency band 20 MHz up to 2 GHz

Mains-borne interference in accordance with ISO 7637-2:

Pulse	1	2a	2b	3a	3b	4
Severity level	III	III	III	III	III	III
Failure criterion	C	A	C	A	A	C

EN 61000-4-2: CD: 8 kV / AD: 15 kV

Severity level II III

EN 61000-4-3: 30 V/m (80...2500 MHz)

Severity level IV

EN 61000-4-4: 2 kV

Severity level III

EN 61000-4-6: 10 V (0.01...80 MHz)

Severity level III

EN 55011: Klasse A

Dimensions

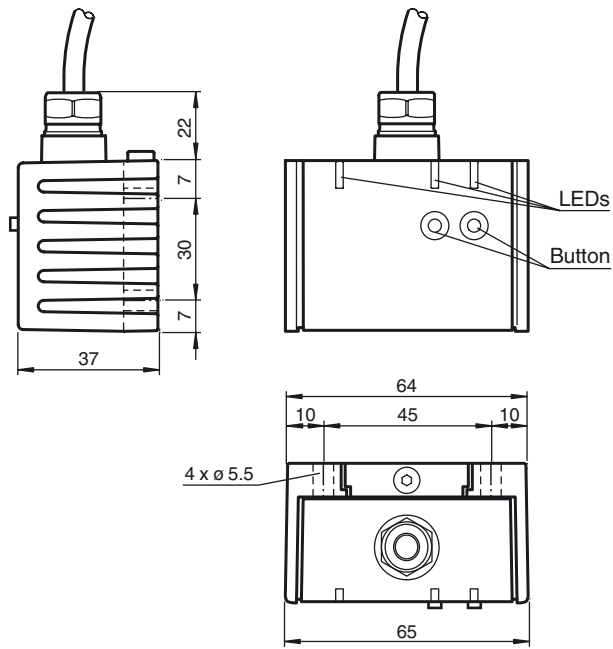

Electrical connection

Standard symbol/Connection:

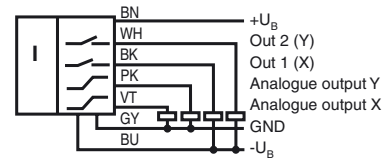

Sensor Orientation

In the default setting the zero position of the sensor is reached, when the electrical connection faces straight upwards.

- On request, all required mounting positions can be preset at the factory.
For example: X = 0 if the electrical connection points straight downwards.

X Orientation



X = 0°

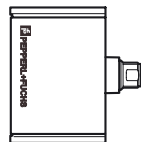

X = 90°

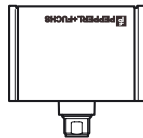

X = ±180°

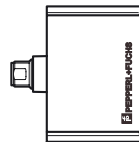

X = 270° (-90°)

Y Orientation

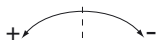

Y = 0°

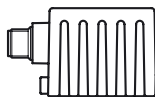

Y = 90°

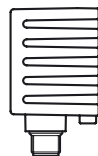

Y = ±180°

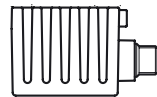

Y = 270° (-90°)

Mounting of the sensor

Inclination sensors from the -F99 series consist of a sensor module and accompanying cast aluminum housing. Select a flat surface with minimum dimensions of 70 mm x 50 mm to mount the sensor. Mount the sensor as follows:

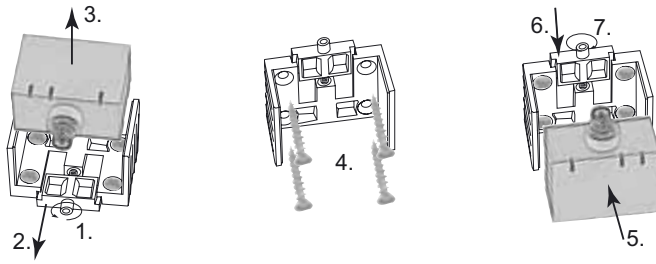

1. Loosen the central screw under the sensor connection.
 2. Slide back the clamping element until you are able to remove the sensor module from the housing.
 3. Remove the sensor module from the housing.
 4. Position the housing at the required mounting location and secure using four countersunk screws. Make sure that the heads of the screws do not protrude.
 5. Place the sensor module in the housing.
 6. Slide the clamping element flush into the housing. Check that the sensor element is seated correctly.
 7. Finally tighten the central screw.
- The inclination sensor is now mounted correctly.