

## Description

Single or multipole hydraulic-magnetic circuit breakers with trip-free-mechanism and toggle actuation. A choice of switching characteristics ensures suitability for a wide range of applications. Industry standard dimensions and panel mounting. Auxiliary contacts optional. Low temperature sensitivity at rated load. Approved to CBE standard EN 60934 (IEC 60934) S-type HM CBE.

## Typical applications

In the business fields Communication and Transport: power supplies, switchgear, instrumentation and process control engineering.

## Standard current ratings and typical internal resistance values

Current rating (A)	Trip curves and internal resistance ( $\Omega$ ) per pole	
	K1, M1, T1,	K2, M2, T2
0.05	452	376
0.1	100	94
1	0.95	0.90
2	0.26	0.20
3	0.10	0.10
5	0.042	0.040
10	< 0.02	< 0.02
15	< 0.02	< 0.02
20	< 0.02	< 0.02
25	< 0.02	< 0.02
30	< 0.02	< 0.02
40	< 0.01	< 0.01
50	< 0.01	< 0.01
60	< 0.01	< 0.01
80	< 0.01	< 0.01
100	< 0.01	< 0.01
125	< 0.01	< 0.01

## Interrupting capacity to EN 60934, UL 489 and UL 1077

### IEC 60934 – test series E

voltage	number of poles	$I_N$ max. (A)	$I_{cn}$ (A)
DC 80 V	1 + 2	0.02...125	10,000
AC 240/415 V	1 - 6	0.02...80	$6 \times I_N$
AC 240 V	1	0.02...20	5,000

### UL 489 – test sequence Z

voltage	number of poles	$I_N$ max. (A)	$I_{cn}$ (A)
DC 80 V	1 + 2	0.5...125	10,000
AC 120 V	1	0.5...80	5,000
AC 120/240 V	1	0.5...80	5,000
AC 240 V	1 (2)	0.5...20	5,000

### UL 1077

voltage	number of poles	$I_N$ max. (A)	$I_{cn}$ (A)
DC 80 V	1 + 2	0.02...125	10,000
AC 277/480 V	1 - 6	0.02...70	5,000



## Technical data

Voltage rating	3 AC 415 V; AC 277/480 V; AC 120/240 V; AC 240 V; DC 80 V,
Current rating range	0.05...125 A single and multipole 150...180 A single pole, two poles connected in parallel higher ratings upon request
Auxiliary circuit	AC 240 V 6 A DC 28 V 3 A DC 65 V 1 A DC 80 V 0.5 A
Typical life	10,000 operations at $1 \times I_N$
Ambient temperature	-40...+85 °C (-40...+185 °F)
Insulation co-ordination (IEC 60664)	2.5 kV/2 reinforced insulation in operating area
Dielectric strength	test voltage
operating area	AC 3,000 V
pole to pole	AC 1,500 V
main to auxiliary circuit	AC 3,000 V
switching to trip circuit	AC 1,500 V
Insulation resistance	> 100 M $\Omega$ (DC 500 V)
Degree of protection (IEC 60529)	operating area IP40 terminal area IP00
Vibration	
with toggle down:	10 g (57-2000 Hz) $\pm$ 0,76 mm (10-57 Hz) at $0.9 I_N$
directions 1, 2, 3, 4, 5:	10 g at $1 \times I_N$
with curves F1, F2:	10 g at $0.8 \times I_N$ in all planes. (57-2000 Hz) $\pm$ 0.76 mm (10-57 Hz) to IEC 60068-2-6, test Fc 10 frequency cycles/axis
Shock	
directions 1, 2, 3, 4, 5:	100 g (11 ms) at $1 \times I_N$ ,
direction 6:	100 g (11 ms) at $0.8 \times I_N$ ,
with curves F1, F2:	100 g (11 ms) at $0.8 \times I_N$ to IEC 60068-2-27, test Ea
Corrosion	96 hours at 5% salt mist, to IEC 60068-2-11, test Ka
Humidity	240 hours at 95 % RH, to IEC 60068-2-3, test Ca
Mass	approx. 90 - 120 g per pole depending on version

## Approvals

VDE (EN 60934)	1- to 6-pole
UL 489	
UL 1077	1- to 6-pole
CCC	1- to 4-pole

## Ordering information

Type No.  
8345

### Mounting

- B** flange mounting, with rectangular aperture with mounting nut 6-32UNC
- C** flange mounting, with rectangular aperture with mounting nut M3
- E** flange mounting, with round aperture with mounting nut 6-32UNC
- F** flange mounting, with round aperture with mounting nut M3

### Configuration

- 0** without barrier
- 1** with small barrier
- 2** with large barrier (requested for multipole AC applications with approvals to UL 489, UL 1077, IEC)

### Number of poles

- 0** single pole unprotected
- 1** single pole protected
- 2** two pole protected
- 3** three pole protected
- 4** four pole protected
- P** one pole protected, two poles connected in parallel characteristic curves E/H/R upon request
- Q** one pole protected, three poles connected in parallel characteristic curves E/H/R upon request
- R** one pole protected, four poles connected in parallel characteristic curves E/H/R upon request
- S** one pole protected, five poles connected in parallel characteristic curves E/H/R upon request

### Actuator configuration

- A** all poles with standard toggle
- B** reduced number of standard toggles
- Z** without actuator

### Terminal design

- L** screw terminals  $M5 \leq 50$  A
- M** solder terminals  $\leq 75$  A
- P** blade terminals  $\leq 35$  A
- R** round connectors 6 mm
- S** stud terminals  $M5 \leq 60$  A
- T** stud terminals 10-32UNF-3A  $\leq 60$  A
- U** stud terminals  $M6 \leq 125$  A
- V** stud terminals 1/4-20UNC-3A  $\leq 125$  A
- W** laminated round terminals  $\leq 125$  A

### Terminal hardware

- 0** without
- 3** with washer and nut
- 6** Phillips screws

### Characteristic curve

- K1** short delay DC
- K2** short delay AC
- M0** medium delay AC/DC
- M1** medium delay DC
- M2** medium delay AC
- Q0** switch only
- T1** long delay DC
- T2** long delay AC

### Version

- D** standard

### Colour configuration

- B1** black actuator
- B2** white actuator
- B3** blue actuator

### Marking

	front plate	actuator base
<b>A1</b>	without	without
<b>A2</b>	$I_N$	without
<b>A3</b>	$I_N$ , characteristic curve	without
<b>A4</b>	$I_N$ , characteristic curve, wiring diagram on side	without
<b>B1</b>	without	ON-OFF
<b>B2</b>	$I_N$	ON-OFF
<b>B3</b>	$I_N$ , characteristic curve	ON-OFF
<b>B4</b>	$I_N$ , characteristic curve, wiring diagram on side	ON-OFF

8345 - C 0 1 A - U 3 M1 - D B1 A1 ...

8345 - C 0 1 A - U 3 M1 - D B1 A1

### Rated voltage

**B** AC or  $\leq 80$  V DC

**C** DC  $\leq 80$  V  
AC  $\leq 277$  V  
(only for configurations 0 and 1)

### Current ratings

0.05...125 A  
higher current ratings upon request

### Approvals (optional)

**V** UL 489

8345 - C 0 1 A - U 3 M1 - D B1 A1 B - 60 A - . ordering example

Remote trip coil available to special order!

## Ordering information for auxiliary contact module

Type number

X8345

### Module

**S** auxiliary contact module

### Auxiliary contacts

- 01** in all poles
- 02** in pole 1 only
- 03** in poles 1+ 3 only
- 04** in pole 2 only

### Auxiliary contact version

- H** auxiliary contacts standard, gold-flushed (asymmetrical terminals not for UL 489)
- K** auxiliary contacts, tin-plated (symmetrical terminals)

### Auxiliary contact function

- W1** 1 changeover
- W2** 2 changeover

### Terminal design

- 02** microswitch with blade terminals DIN 46244-A2.8-0.5
- M** mounted to base unit

X8345 - S 01 H W1 02 M ordering example

## Dimensions

### Mounting version B/C

Flange mounting rectangular aperture

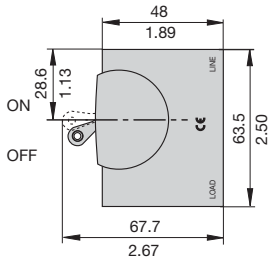

number of poles 1 to 4

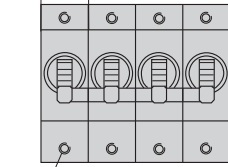
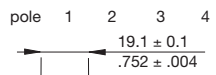

mounting thread M3 or 6-32  
all dimensions referred to the top edge  
mounting depth 4.2 mm/.165 in.  
max. insertion depth 5.5 mm  
max. tightening torque 0.33 Nm

### Cut-out dimensions:

1-pole

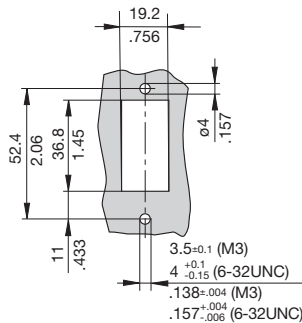

multipole

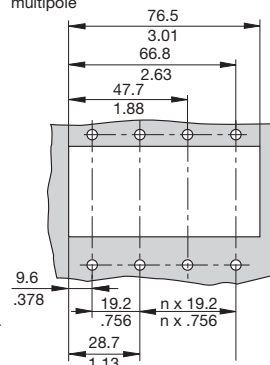

### Mounting version E/F

Flange mounting round aperture

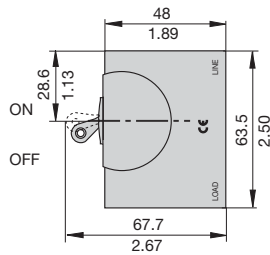

number of poles 1 to 4

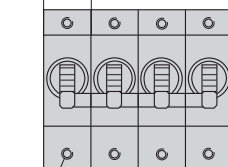
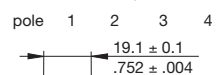

mounting thread M3 or 6-32  
all dimensions referred to the top edge  
mounting depth 4.2 mm/.165 in.  
max. insertion depth 5.5 mm  
max. tightening torque 0.33 Nm

### Cut-out dimensions:

1-pole

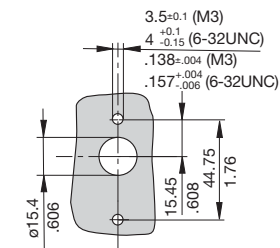

4-pole

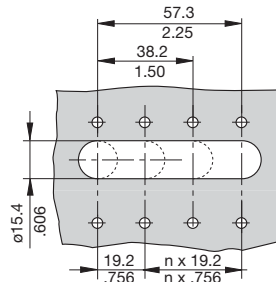

## Installation drawing

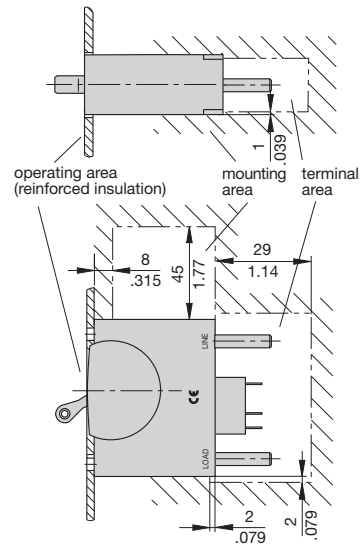

## Actuator configuration

### A 1 toggle per pole, mounting version B/C

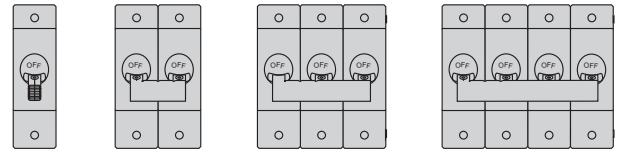

### B reduced number of toggles per unit, mounting version B/C

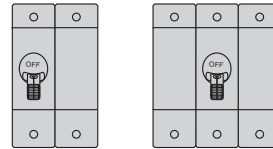

### Z without toggles

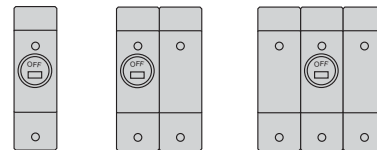

### A 1 toggle per pole, mounting version E/F

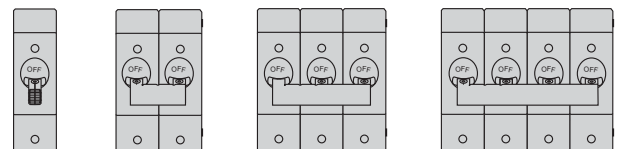

### B reduced number of toggles per unit, mounting version E/F

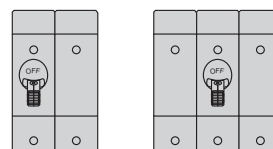

This is a metric design and millimeter dimensions take precedence ( $\frac{\text{mm}}{\text{inch}}$ )

## Terminal design / Dimensions

### P - with blade terminals

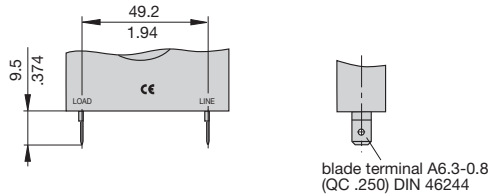

### L - with screw terminals

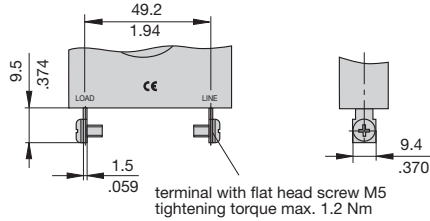

### M - with solder terminals

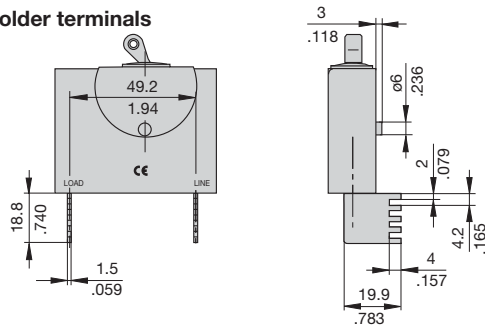

### R - round connectors D = 6 mm (dia .236) (version H) asymmetrical terminals (not for UL 489)

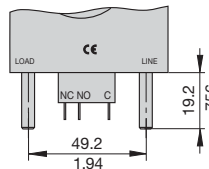

### S/U/T/V - with auxiliary contacts (version H) asymmetrical terminals (not for UL 489)

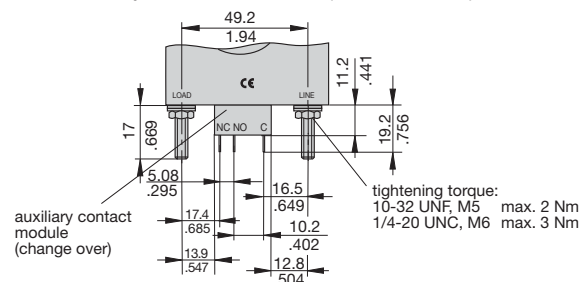

### auxiliary contacts version K symmetrical terminals

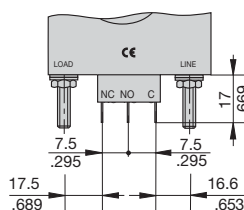

### W - laminated round terminals

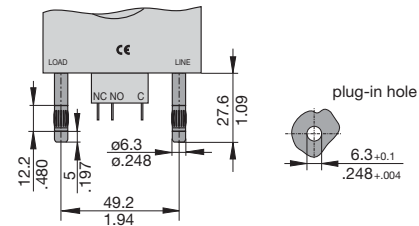

## Number of poles / Dimensions

### P 1-pole protected, 2-poles connected in parallel for rating currents from 150 to 180 A

tightening torque:  
M8 max. 6 Nm

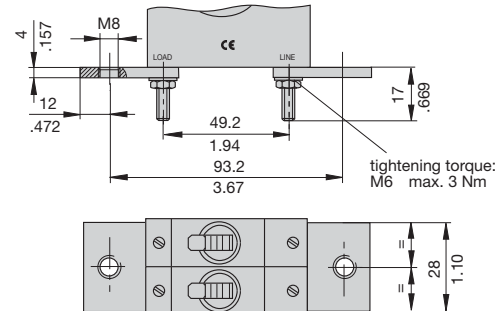

## Internal connection diagrams

### 1-pole protected magnetically

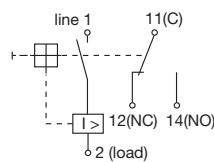

### multipole

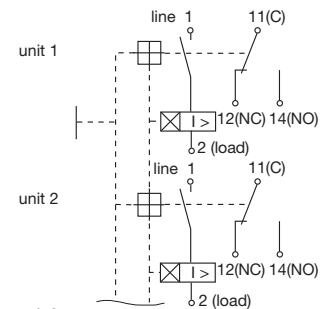

### 1-pole protected hydraulic-magnetically

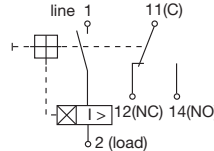

This is a metric design and millimeter dimensions take precedence (mm/inch)

## Typical time/current characteristics at +23 °C / +73.4 °F

(trip time at rated current and all poles symmetrically loaded)

**Curve K1 (short delay) for DC**

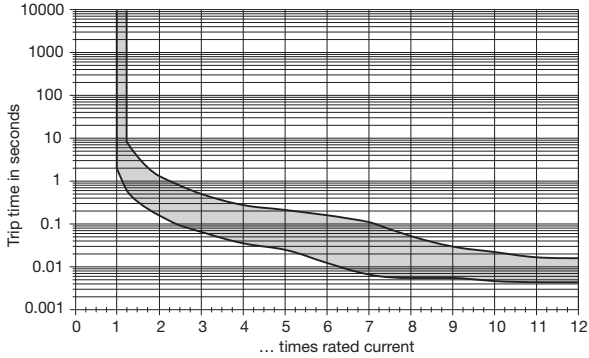

**Curve M0 (medium delay) for AC/DC**

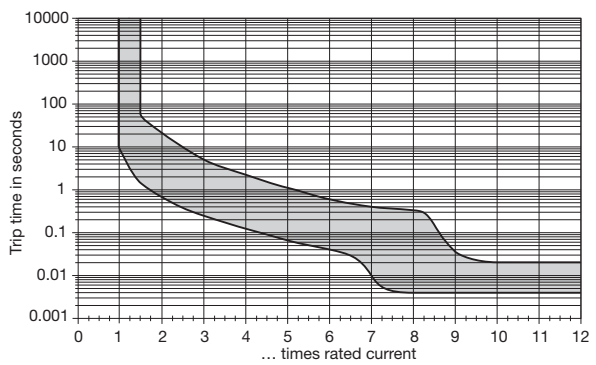

**Curve K2 (short delay) for AC 50/60 Hz**

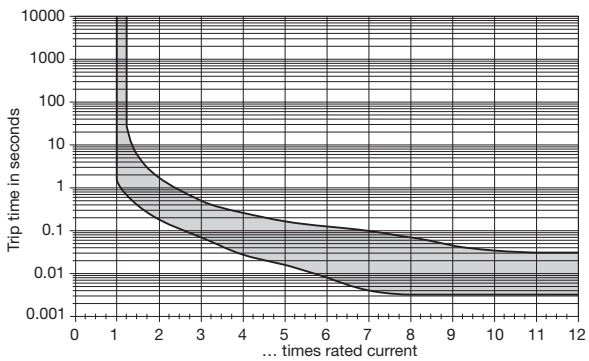

**Curve M1 (medium delay) for DC**

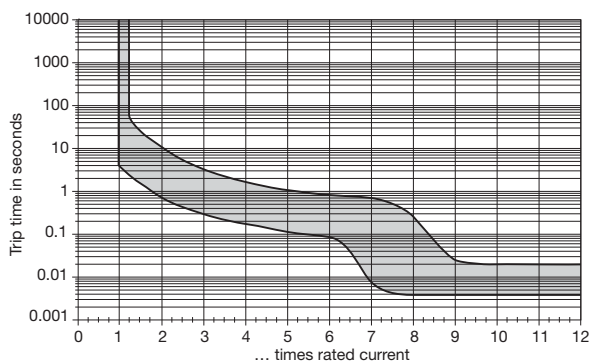

**Curve T1 (long delay) for DC**

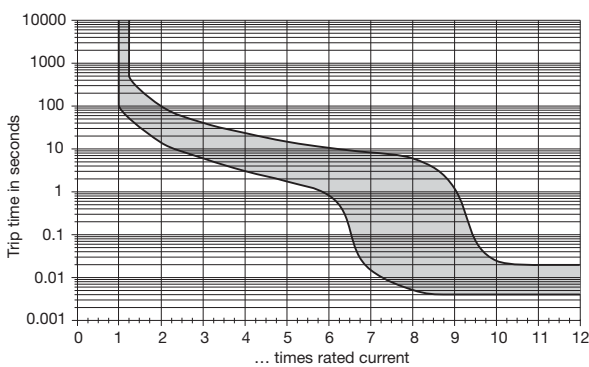

**Curve M2 (medium delay) for AC 50/60 Hz**

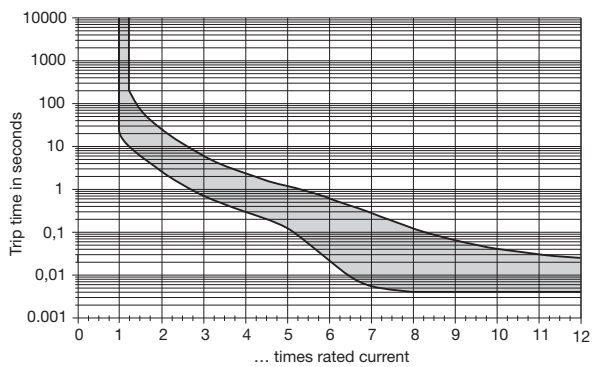

**Curve T2 (long delay) for AC 50/60 Hz**

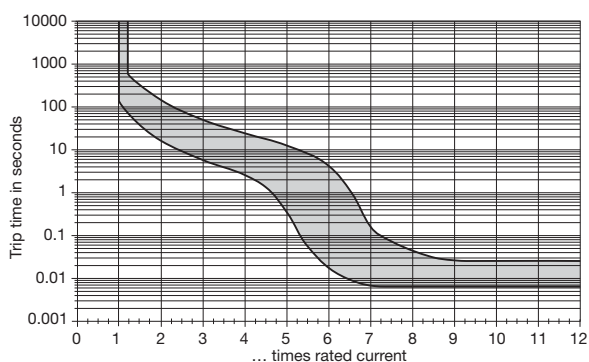

All curves will only be maintained if the escutcheon is mounted on a vertical surface.

**Other characteristic curves to special order ( e. g. pulse delayed, for high inrush currents or capacitive loads).**

## Interphase barriers / Dimensions

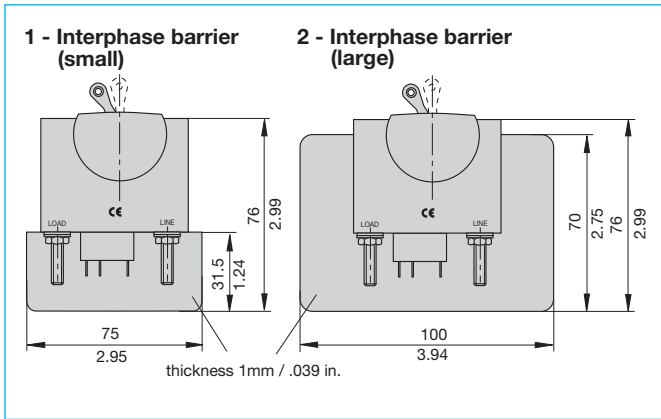

## Shock directions

3

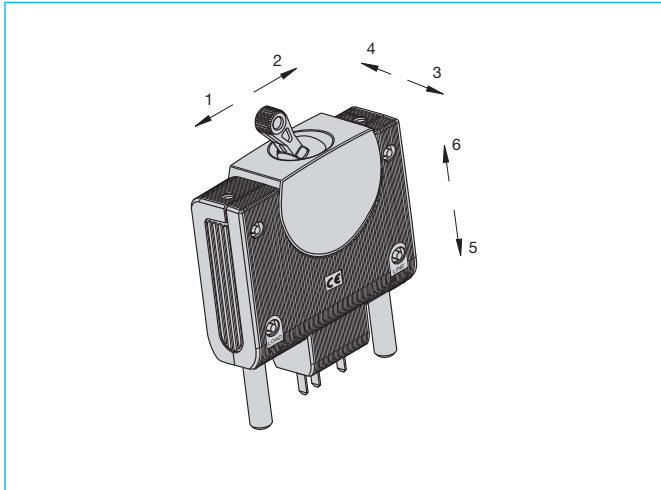

## Accessories

**Splash cover (IP65) for 1-, 2-, 3-pole (only for mounting version B/C)**

	number of poles	mounting version	actuator configuration
X 222 444 01	1-pole	B	1
X 222 444 02	1-pole	C	1
X 222 444 11	2-pole	B	2
X 222 444 12	2-pole	C	2
X 222 444 21	3-pole	B	3
X 222 444 22	3-pole	C	3

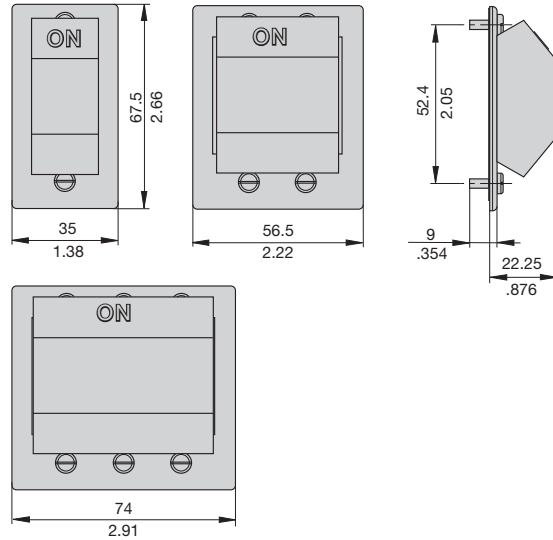

**Toggle guard (only for mounting version B/C)**  
Y 307 381 01

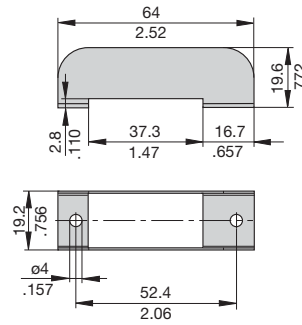

This is a metric design and millimeter dimensions take precedence ( $\frac{\text{mm}}{\text{inch}}$ )

All dimensions without tolerances are for reference only. In the interest of improved design, performance and cost effectiveness the right to make changes in these specifications without notice is reserved. Product markings may not be exactly as the ordering codes. Errors and omissions excepted.

## Description

A module which adds remote trip capability to all versions of type 8345. A voltage applied across the coil, by means of an external sensor for example, will cause disconnection of the main switch/circuit breaker mechanism.

## Typical applications

Electrical monitoring of safety systems, remote trip.

## Ordering information

<b>Type No.</b>	
<b>X8345</b>	Module for type 8345
<b>Module</b>	
<b>F</b>	remote trip module
<b>Assembly version</b>	
<b>01</b>	only in pole 1
<b>02</b>	only in pole 2
<b>03</b>	only in pole 3
<b>04</b>	only in pole 4
<b>Remote trip version</b>	
<b>X1</b>	DC
<b>Voltage rating</b>	
<b>12</b>	12 V
<b>24</b>	24 V
<b>Terminal design</b>	
<b>02</b>	blade terminals DIN 4644-A2.8-0.5
<b>M</b>	module mounted to circuit breaker
<b>X8345 - F 01 X1 12 02 M</b>	ordering example

## Voltage ratings and typical internal resistance values

Voltage ratings	Internal resistance ( $\Omega$ )
DC 12 V	3.4
DC 24 V	13.9

This is a metric design and millimeter dimensions take precedence ( $\frac{\text{mm}}{\text{inch}}$ )

All dimensions without tolerances are for reference only. In the interest of improved design, performance and cost effectiveness the right to make changes in these specifications without notice is reserved. Product markings may not be exactly as the ordering codes. Errors and omissions excepted.

## Dimensions

Additional remote trip module

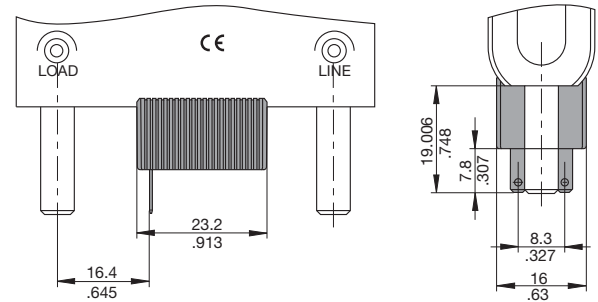

## Internal connection diagram

1-pole protected hydraulic-magnetically with additional remote trip coil

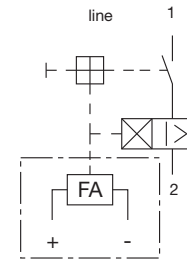

## Technical data

Voltage ratings	DC 12 V and DC 24 V
Power consumption	approx. 40 W
Pulse operation	20 ms < t <sub>ON</sub> < 100 ms / t <sub>OFF</sub> > 10 sec (Continuous duty possible for multipole devices upon request)
Typical life	10,000 operations at U <sub>N</sub>
Ambient temperature	-40...+85 °C (-40...+185 °F)
Insulation co-ordination (IEC 60664)	2.5 kV/2 (EN 60934)
Dielectric strength between main circuit and trip coil circuit	test voltage AC 3,000 V (EN 60934)
Insulation resistance	> 100 M $\Omega$ (DC 500 V)
Vibration	6 g (57-2000 Hz) $\pm$ 0.46 mm (10-57 Hz) shock direction 1/2 4 g (57-2000 Hz) $\pm$ 0.30 mm (10-57 Hz) shock direction 3/4 3 g (57-2000 Hz) $\pm$ 0.23 mm (10-57 Hz) shock direction 5/6 to IEC 60068-2-6, test Fc 10 frequency cycles/axis
Shock	100 g (11 ms) (not when mounted upside down) to IEC 60068-2-27, test Ea
Corrosion	96 hours at 5 % salt mist, to IEC 60068-2-11, test Ka
Humidity	240 hours at 95 % RH to IEC 60068-2-3, test Ca
Mass	approx. 8.5 g (without base unit)



## Description

The X8345-R is an additional module which provides remotely controlled ON and OFF functionality for the E-T-A series 8345 magnetic circuit breaker range. The module actuator, which is motor driven, is factory fitted adjacent to the circuit breaker(s) which it is controlling. The module can be operated by a suitable external changeover switch, momentary switches (one ON, one OFF) or logic system (not part of our product). The status of the actuator will follow the position of the external switch, i.e. if the circuit breaker trips electrically or is operated manually, the actuator will not change.

A single module will control a single pole breaker or multipole circuit breakers up to 3 poles. In the application it has to be ensured that the supply voltage is maintained at all times.

When switching the circuit breaker OFF manually the module has also to be switched off by means of the changeover switch before switching the breaker on again. The same is true for normal switch-on of the breaker.

**NEW**



**X8345-R**

## Ordering information

### Type number

**X8345** Module for type 8345

### Module

**R** remote ON/OFF actuation

### Operating voltage

**24** DC 24 V

### Add-on version

**01** mounted on right side

### Mounting method

**00** front panel mounting (standard)

**01** single bracket: module fitted

**02** 2-bracket: module and circuit breaker fitted

### Terminal design

**01** spring loaded screwless terminal 5-pin

### Supply status

**M** module mounted to the base unit

**X8345 - R 24 01 00 01 M** ordering example

Note: Bold-type, blue configurations are standard versions which are presently available.

## Technical data

Voltage rating	DC 24 V (16...32 V)
ON duty	50 %
Trip time	< 2 sec
Blocking current	< 1.5 A
Control current	< 3 mA
Typical life	10,000 operations (ON/OFF)
Ambient temperature	-25...70 °C (-13...158 °F)
Insulation co-ordination (IEC 60664)	2.5 kV/2 (EN 60934)
Dielectric strength pole to module	test voltage AC 1,500 V (EN 60934)
Insulation resistance	> 100 MΩ (DC 500 V)
Vibration	10 g (57-2000 Hz), ± 0,76 mm (10-57 Hz) to IEC 60068-2-6, test Fc, 10 frequency cycles/axis
Shock	100 g (11 ms) to IEC 60068-2-27, test Ea
Corrosion	96 hours at 5% salt mist, to IEC 60068-2-11, test Ka
Humidity	240 hours at 95 % RH, to IEC 60068-2-3, test Ca
Mass	approx. 65 g (without base unit)

## Internal connection diagrams

single pole, hydraulic-magnetic protection, with remote ON/OFF actuation (operated by changeover switch)

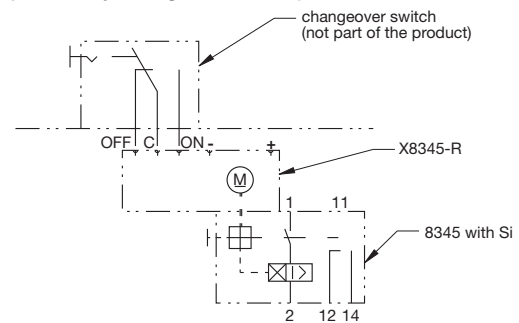

single pole, hydraulic-magnetic protection, with remote ON/OFF actuation (actuated by two momentary switches)

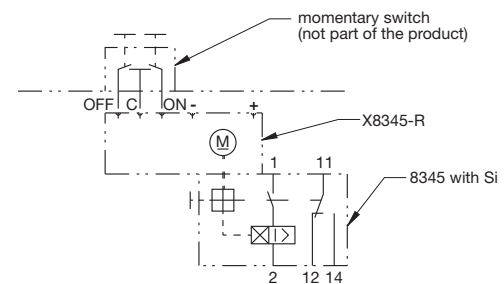

## Typical applications

Remote circuit breaker control (ON/OFF) for communication systems, marine installations, automation equipment and similar requirements.

## Dimensions

3

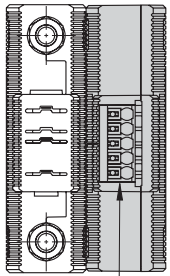
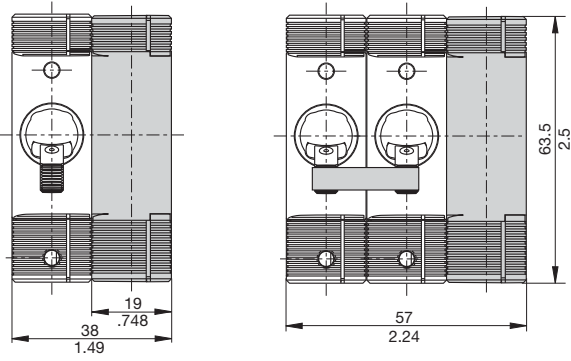

spring loaded screwless terminal  
5-pin

**X8345-R-24-01-00-01-M**

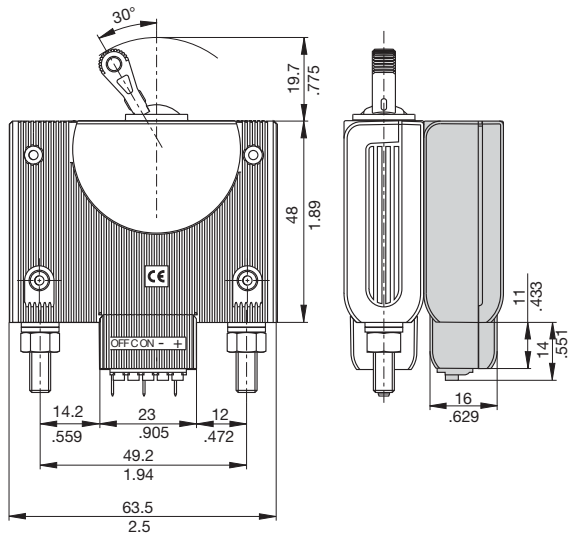

**X8345-R-24-01-01-01-M**

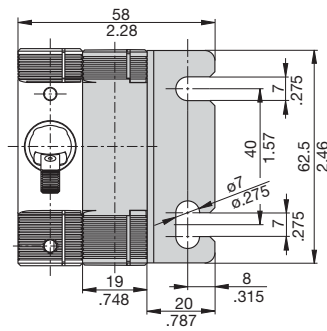
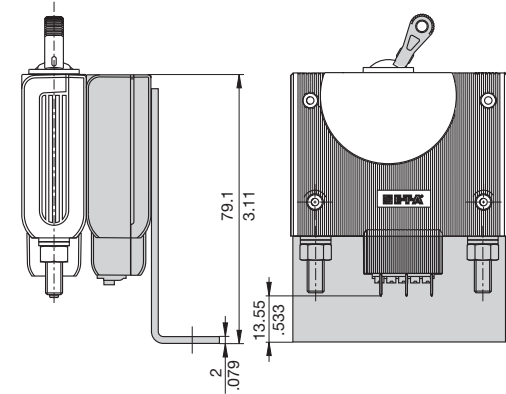

**X8345-R-24-01-02-01-M**

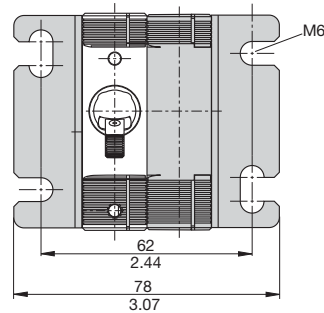
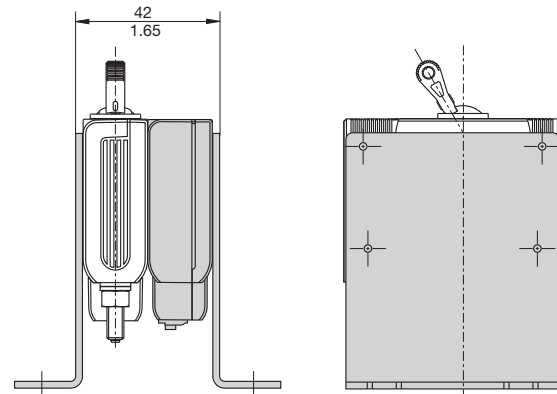

All dimensions without tolerances are for reference only. In the interest of improved design, performance and cost effectiveness the right to make changes in these specifications without notice is reserved. Product markings may not be exactly as the ordering codes. Errors and omissions excepted.